

STAR TREK[®] II

SOURCEBOOK UPDATE



For use with
STAR TREK[®]
THE ROLE PLAYING GAME

TABLE OF CONTENTS

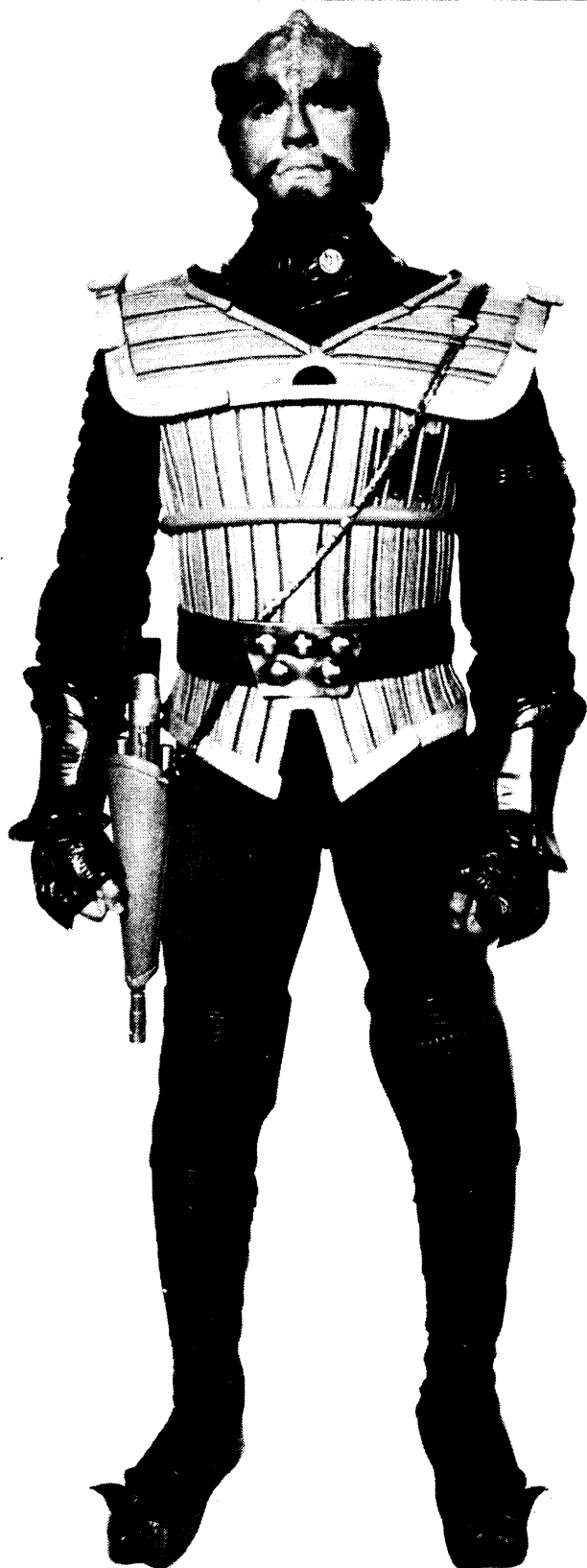

Officer's Orientation Briefing	3
Organization Of This Manual	3
Time Line Of <i>STAR TREK</i> History	4

STAR TREK Terminology	6
Genesis Device	6
Prefix Code	7
Reference Stardate	7
Governments	8
Klingon Empire	8
Romulan Star Empire	9
Gorn Alliance	9
Orion Colonies	9
Tholian Assembly	9
United Federation of Planets	9
Star Fleet Command	10
Uniforms and Insignia	10
Equipment	11
Personal Equipment	11
Armor, Security	11
Belt Monitor	11
Communicator	12
Environmental Suit	13
Radiation-Shielded Suit	13
Tricorder, Advanced Models	13
Sidearms	15
Federation Star Fleet	15
<i>Phaser I-B</i>	15
<i>Phaser II-B</i>	15
<i>Phaser Rifle</i>	15
Klingon Empire	15
<i>Mark I Hand Disruptor</i>	15
<i>Mark I Disruptor Rifle</i>	16
<i>Mark II Hand Disruptor</i>	16
<i>Mark III Hand Disruptor</i>	16
<i>Mark III Disruptor Rifle</i>	16
Gorn Alliance	17
<i>Mark I Blaster</i>	17
<i>Mark II Blaster</i>	17
<i>Sonic Stunner</i>	17
Shipboard Systems	17
A-Grav Carrier	17
A-Grave Platform	17
Security Lock Panels	17
Thruster Suit	17
Transporter, Improved Models	17
Starship Recognition File	18
United Federation Of Planets	18
Technical Data	18
Shuttles and small craft	19
<i>SW-7 Class Shuttle And Warpsled</i>	19
<i>S-10 Travel Pod</i>	19
Starships	20
<i>Excelsior Class Battleship</i>	20
<i>Enterprise Class Heavy Cruiser</i>	21
<i>Reliant Class Research Cruiser</i>	22
<i>Gagarin Class Research Vessel</i>	23
<i>Lotus Flower Class III Neutronic Fuel Carrier</i>	24
Space Stations	25
Star Fleet Repair And Service Facility: Sol III	26
<i>R1 Type Orbital Station</i>	26
<i>Samson Class Warp-Tender</i>	27
Klingon Empire	28
Starships	28
<i>D-7M (K't'inga) Class Light Cruiser</i>	28
<i>D-32 (Z'Gavva) Class Light Cruiser</i>	29
Star Fleet Personnel File	30
Adventure: <i>Lost And Presumed Dead</i>	35
Weapons Chart	47
Character-Creation Short Form (Revised)	48





STAR FLEET SOURCEBOOK UPDATE

Supplement Design and Writing

Fantasimulations Associates

Guy W. McLimore, Jr.

Greg K. Poehlein

Starship Statistics Design

FASA Design Team

Forest Brown

Fantasimulations Associates

David Tepool

Guy W. McLimore, Jr.

Lost And Presumed Dead Adventure

Greg K. Poehlein

Editing

Wm. John Wheeler

Production

Graphics And Layout

Dana Knutson

Jordan Weisman

Typesetting

Karen Vander Mey

Proofreading

Donna Ippolito

STAR TREK is a trademark of Paramount Pictures Corporation.
STAR TREK III: The Search For Spock products are published by
FASA Corporation under exclusive license from Paramount Pictures
Corporation, the trademark owner.
STAR TREK: The Role Playing Game is published by
FASA Corporation under exclusive license from Paramount Pictures
Corporation, the trademark owner.

Copyright © 1966, 1984 Paramount Pictures Corporation
All Rights Reserved
Printed in the United States of America

STAR TREK is a trademark of Paramount Pictures Corporation
STAR TREK: The Role Playing Game is published by
FASA Corporation under exclusive license from Paramount Pictures
Corporation, the trademark owner.

OFFICER'S ORIENTATION BRIEFING

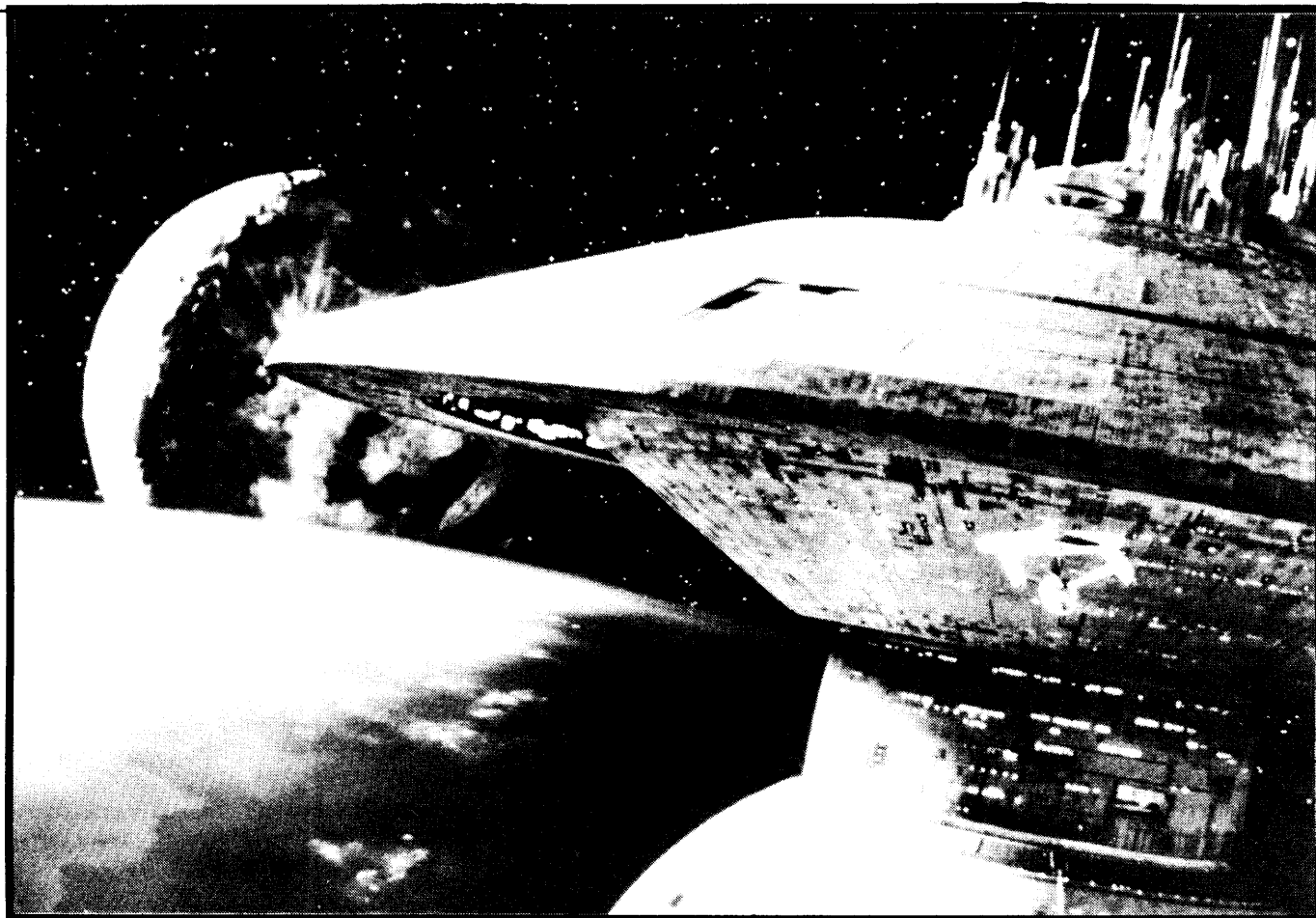

The organization of this supplement parallels that of the second edition of the **Cadet's Orientation Sourcebook** from the Second Edition rules (hereafter called ST:RPG2), but it can be used just as easily with the First Edition rules (hereafter called ST:RPG1). Entries are of three general types: *additions*, containing completely new material; *updates*, expansions on existing information, bringing it up to date with the movie universe; and *revisions*, changes in information that replace material from ST:RPG2. Where possible, the revisions contain all the pertinent information from ST:RPG2, so that the entry here may be used instead of the entry in that set of rules. In this book, sections noted as ■ are entirely new entries or additions to previous entries, bringing them up to date. Sections marked ○ replace the old entry of the same name, either because the information has been revised or because it has been brought up to date.

Officers will find that everything they expect from the *STAR TREK* universe supplement is present here. The Klingons are dangerous, Kirk is valiant, and space is vast and mysterious. This set enhances the fun and excitement by introducing a whole new dimension to play. The adventure is just beginning, and there are always possibilities.

ORGANIZATION OF THIS MANUAL

This chapter provides additions to *STAR TREK* terminology and history up through the events of *STAR TREK III*. It includes the complete historical time line of the United Federation of Planets, as well as new terminology from the three films.

The second chapter provides updates on the most important starfaring governments, including the UFP.

The third chapter provides information on Star Fleet equipment, including the new Star Fleet uniforms and insignia. As might be expected, the equipment used by Star Fleet has been improved and revised, sometimes more than once, in the years since the end of the *Enterprise's* five-year mission under Capt. James T. Kirk. This section will deal with such changes and improvements to personal equipment, to sidearms, and to shipboard systems. Equipment used by non-UFP races (Klingons, Romulans, etc.) will not be covered in this set except for basic sidearms.

The fourth chapter is a Recognition File for some of the ships introduced in the *STAR TREK* films. The new ships of Star Fleet and her interstellar rivals are among the most interesting features of the *STAR TREK* films. In this section, complete statistics are provided for the new ships. It includes both technical data of interest to role-players and game data for use with the ST:RPG1 starship combat system and the **Ship Construction Manual** or the **Starship Combat Game**, both published by FASA.

The fifth chapter contains personal data files on characters from the *STAR TREK* films. Included are updates on the characters from the TV series, as well as additions for the new characters from the films.

Finally, a complete adventure scenario is included for campaigns set at the time of the *STAR TREK* movies. This adventure takes advantage of the many changes in the universe since the TV series.

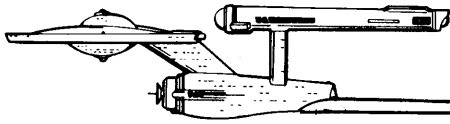
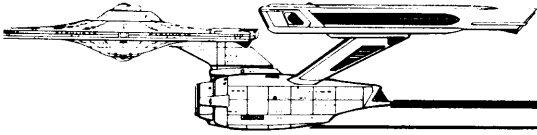

TIME LINE OF STAR TREK HISTORY

These pages update the Time Line found in the **Cadet's Orientation Sourcebook**, which these pages replace. All officers are directed to amend their **Sourcebook**, discarding the outdated material.

The Time Line has been extended to Reference Stardate 2/2206.27. All dates are given as standard Reference Stardates (see **STAR TREK Terminology** section for explanation).

Stardate -1/3011.19

Visionary social worker Edith Keeler is killed in an accident while crossing the street. The event is witnessed by Kirk, Spock and McCoy while time-travelling using the Guardian of Forever.

Stardate -1/6701.26

Captain John Christopher, an Air Force interceptor pilot, reports a UFO, but it soon disappears from view. The UFO is the *Enterprise*, warped back in time and appearing in Earth's atmosphere over the United States Of America.

Stardate -1/6803.29

Travelling in time, the crew of the *Enterprise* encounters Supervisor 194, Gary Seven, on an assignment to prevent 20th-century Earth (henceforth called Terra) from destroying itself in nuclear war.

Stardate -1/6907.20

Neil Armstrong becomes the first Human to step foot on Terra's moon, starting Human manned interplanetary exploration.

Stardate -1/9206 - 9609

The outbreak of the Eugenics Wars limits manned space efforts for a time, as resources are turned to global war.

Stardate -1/9609.22

SS Botany Bay, a converted *DY-100* interplanetary vessel with cryogenic sleep capsules installed, leaves Terra carrying 97 refugees from among the genetic 'supermen' who sparked and led the Eugenics Wars. In command is Khan Noonian Singh, the greatest dictator of the Wars.

Stardate -1/9704.18

The first permanent base on Terra's Moon is established, jointly funded by the United States Of America and Japan. This marks the rededication of Terran peoples to space exploration as part of the rebuilding following the Eugenics Wars.

Stardate -1/9904

Large-scale asteroid mining opens up Sol's Asteroid Belt to colonization. Several more lunar stations are opened this year by various nations and several private corporations. Armstrong Center, remaining the largest, has become a small city of scientists, technicians and support personnel, and already is beginning to cater to a growing tourist trade.

Stardate 0/0001.01

January 1, 2000, the base date for Reference Stardate system. On this date, the Science Council of Luna declares itself independent of the governments of the United States Of America and Japan and requests status as a United Nations protectorate. Such status is granted, forming the first interplanetary Human government.

Stardate 0/2011.17

The *Nomad* probe is launched from Terran orbit. It is lost in space and presumed destroyed.

Stardate 0/3605

New space-time researches find holes in the general theory of relativity, making faster-than-light communication and travel theoretically possible, though not yet an actuality.

Stardate 0/4202.25

The first manned expedition is launched to Alpha Centauri in a high-acceleration, sub-light-speed *Bussard ramjet*.

Stardate 0/4806.23

Contact is established with a humanoid culture on Alpha Centauri by the first manned, Terran expedition.

Stardate 0/4812

Alpha Centauri scientist Zephram Cochrane formulates the initial warp drive calculations, making faster-than-light travel possible and, eventually, practical.

Stardate 0/5507 through 5909

The first experimental warp-drive ships are tested by Terra and Alpha Centauri research teams.

Stardate 0/6201

The Fundamental Declarations of the Martian Colonies establishes independent government for all off-planet Terran colonies. Zephram Cochrane disappears.

Stardate 0/6511

First contact occurs with the Vulcans, when a warp-drive probe encounters a Vulcan colony world. Vulcan has already developed the warp drive, and Vulcan techniques substantially improve on the original design.

Stardate 0/7104 through 7301

First commercial space ventures by Vulcan, Terra, and Alpha Centauri.

Stardate 0/7308

First contact occurs with the Tellarites.

Stardate 0/7511

First contact occurs with the Andorians nearly ends in disaster when an Andorian starship fires on a Terran exploratory vessel. Terra prepares for war, but cooler heads on Vulcan convince Terra leaders to try and negotiate with the growing Andorian empire.

Stardate 0/7703

The First Alpha Centauri Conference preserves the peace, with Vulcan diplomats convincing Andor that it has nothing to gain and everything to lose by fighting Terra and her allies. Andor joins the alliance.

Stardate 0/7907

First contact occurs with the Orion Colony worlds in the Rigel system.

Stardate 0/8706.06

Articles of Federation are signed at the First Babel Conference, establishing the United Federation of Planets. The original signatory powers include Terra, Alpha Centauri, Vulcan, Andor, and Tellar. The Rigel/Orion Colonies, remain outside the Federation entirely.

Stardate 0/9109

Star Fleet Academy is founded.

Stardate 0/9211

First contact with the Romulan Star Empire occurs when a cargo ship is captured by Romulan forces.

Stardate 1/0610

War is declared between the Federation and the Romulan Star Empire.

Stardate 1/0909

The Romulan War is ended inconclusively, after staggering losses on both sides. The treaty, negotiated by subspace radio, establishes a Neutral Zone, and no ships are allowed to cross between the two powers. No Federation forces have seen a Romulan face-to-face throughout the entire war, mostly because the Romulans refuse to allow a ship to be captured intact.

Stardate 1/0910 through 2412

Peace reigns, but the Orion Colonies know that the existence of the Federation will soon be discovered by the Klingon Empire. The Colonies sign non-aggression and trade treaties with the Federation, but do not join the UFP.

Stardate 1/5105

First contact with the Klingon Empire leads immediately to conflict. Orion colonies declare neutrality and trade with both groups. Klingon raids on Federation shipping often masquerade as Orion-based pirates – and vice-versa.

Stardate 1/7407

The transporter (originally called the materializer) is invented.

Stardate 1/7603

Dilithium is first mined and used for power rectifiers in warp drives.

Stardate 1/8801.04

Star Fleet's *Constitution*-class ships become operational with the commissioning of the *USS Constitution*. Less than 1 month later, the *USS Enterprise* is commissioned, under Captain Robert April.

Stardate 1/9001

After a 2-year, shakedown cruise, the first standard, five-year mission of the *Enterprise* begins, under Capt. April.

Stardate 1/9409

Klingon forces ally with the Axanar star system to begin the Four Years War. Captain Garth of Izar prevents the Klingons from establishing supply lines to and from Axanar and is awarded the Federation Medal of Valor.

Stardate 1/9501

Capt. April retires from Star Fleet and becomes a Federation ambassador.

Stardate 1/9506

Capt. Christopher Pike is given command of the *Enterprise*.

Stardate 1/9608

Upon Capt. Pike's recommendation, Talos IV is quarantined by the Federation.

Stardate 1/9806

The Four Years War ends with the success of the Axanar Peace Mission. The phaser replaces the laser as the Federation's primary weapons system.

Stardate 2/0105

Green Slave trade is abolished outside strict limits of Orion neutrality area by UFP intervention. Economic sanctions by the UFP force Orion Colonies to abolish the slave trade – officially.

Stardate 2/0704

After the promotion of Capt. Pike to the position of Fleet Captain over *Constitution*-class vessel operations, his hand-picked successor, Capt. James T. Kirk, becomes the youngest man to ever command a *Constitution*-class vessel.

Stardate 2/0704 through 0803

The adventures occur that are related in the first season of the *STAR TREK* TV series.

Stardate 2/0705

Lt. Cmdr. Gary Mitchell, First Officer of the *Enterprise*, is killed in the line of duty after contact with the Energy Barrier at the edge of the galaxy. Lt. Cmdr. Spock, at the request of Capt. Kirk, is made First Officer as well as Chief Science Officer. He is the first person to ever hold both positions simultaneously on a major Star Fleet vessel.

Stardate 2/0801.09

The Organian Peace Treaty is imposed by the Organians on both Federation and Klingon forces, thus averting a second Klingon war. The Organian Treaty Zone is established by negotiation over the next 3 months.

Stardate 2/0801.24

The first Federation contact with the Gorn occurs.

Stardate 2/0803 through 0903

The adventures occur as related in the second season of the *STAR TREK* TV series.

Stardate 2/0811

In recognition of outstanding service as both First Officer and Chief Science Officer of the *Enterprise*, Lt. Cmdr. Spock is promoted to full Commander.

Stardate 2/0902

The Babel Conference on the Coridan question is settled by the inspired oratory of Sarek of Vulcan. Coridan is made a UFP protectorate. The first of a series of Romulan/Klingon non-aggression and technological exchange treaties are signed in secret.

Stardate 2/0903 through 1003

The adventures occur as related in the third season of the *STAR TREK* TV series.

Stardate 2/1102

The *Enterprise* participates in a Star Fleet intelligence operation to seize a prototype of a new Romulan cloaking device. *Enterprise* escapes with the device and confirmation of a Klingon-Romulan technological agreement. The device works once when they escape from the Romulan Neutral Zone, but it later fails to function when detached from the *Enterprise* for study. The mechanism is examined and duplicated by UFP scientists, but the prototype fails in a particularly nasty fashion, and all research and development aimed toward making cloaking devices operational on Federation ships is halted.

Stardate 2/1003.01

The first Federation contact with the Tholians occurs, though the Vulcans were aware of the presence.

Stardate 2/1003 through 1103

The adventures occur as related in the *STAR TREK* animated series.

Stardate 2/1103 through 1203**Stardate 2/1204**

The *Enterprise* returns from its five-year mission under Capt. James T. Kirk. It is the only ship remaining from the first group of *Constitution*-class vessels; all others have been lost in service.

Stardate 2/1204

Capt. James Kirk promoted to Commodore upon the triumphal return of the *USS Enterprise*. It is the only remaining ship of the first group of *Constitution*-class vessels, all others have been lost in service. Star Fleet, riding the crest of a publicity wave, decorates Kirk and most of the top officers and grants them six-months leave. Star Fleet adopts the *Enterprise* identification symbol as the official Star Fleet emblem, abolishing the practice of individualized emblems for each ship.

Stardate 2/1204 through 1210

Commodore James Kirk spends much of his shore leave successfully using his influence and prestige to assure Star Fleet's continued vigilance, but non-militant, activities in the face of increased Klingon aggression outside the Neutral Zone. Upon his return, he becomes Chief Of Star Fleet Operations to assure that his proposals are carried out. Kirk is promoted to Admiral, and the *Enterprise* prepares to undergo a complete refit.

Stardate 2/1212

Cmdr. Spock refuses an offered promotion to Captain and retires from active duty, entering Star Fleet Reserve. He pursues the Kolinahr discipline on Vulcan.

Stardate 2/1704

The new *Enterprise* heavy cruiser class is established with the christening of the newly-refitted *USS Enterprise*. The ship will be commanded by Capt. Willard Decker, hand-picked for the job by Adm. Kirk. The christening ceremony has to wait, though, when a crisis sends the ship out to investigate V'ger, a huge vessel moving toward Terra and capable of incredible destruction. Spock returns from Vulcan. After the incident, Decker and Lt. Ilia of Delta are listed as "missing in action." The V'ger incident enhances Kirk's fame – and makes him too valuable to risk in active command. After a short shakedown cruise of the new *Enterprise*, Kirk returns to desk duty, eventually assigned to testing and inspection on detached service from Star Fleet Academy. Cmdr. Spock's reserve commission is reactivated; he stays on with a promotion and assignment as Captain of the *Enterprise*.

Stardate 2/2206.16

Cmdr. Pavel Chekov and Capt. Clark Terrell unexpectedly encounter Khan Noonian Singh in the Ceti Alpha system. Using the mind-controlled officers as bait, Khan and the rest of the Ceti Alpha survivors capture the research cruiser *Reliant*.

Stardate 2/2206.20

The *USS Reliant* under Khan Noonian Singh's piratical command ambushes the *USS Enterprise*, manned with Star Fleet Academy cadets on a training cruise. After a battle in the Mutara Nebula, Khan is dead and the *Enterprise* is severely damaged. Faced with the impending detonation of the Genesis Device, Spock enters a deadly radiation-contaminated area and restores power to the warp drive just in time to allow the *Enterprise* to outrun the Genesis Wave. In so doing, Spock absorbs a fatal dose of radiation. His inert body is launched toward the new Genesis world as the Genesis Effect accelerates growth of living things on there.

On its way back to space dock, the *Enterprise* drops off Dr. Carol Marcus and the Academy cadets for debriefing. Dr. David Marcus and Lt. Saavik are transferred to the research vessel *Grissom*, on its way back to the Genesis planet.

Stardate 2/2206.21

Enterprise returns to Earth space dock. Kirk, in disfavor because of the loss of *Reliant*, the Regula I research station, the Genesis Device, and Spock, meets with Surak, Spock's father. The demoralized *Enterprise* crew is reassigned to various posts on Terra and at the space dock, pending further investigation.

Stardate 2/2206.22

Dr. David Marcus and Lt. Saavik find a Vulcan baby on the Genesis planet, who is growing up at a highly accelerated rate. This proves to be the regenerated body of Spock, but minus his intellect and *essence*.

Stardate 2/2206.23

The *Enterprise* is stolen from the space dock by Kirk, McCoy, Scott, Sulu, and Chekov with help of Uhura and returns to Genesis planet to seek Spock's body.

Stardate 2/2206.25

Dr. David Marcus is killed by Klingons on the Genesis Planet, and the *Enterprise* self-destruct system is used to prevent Klingons from capturing the ship. Kirk, Sulu, Saavik, McCoy, Chekov, and Scott escape aboard a captured Klingon *Bird of Prey*, along with the regenerated Spock. The Genesis Effect proves its instability and the Genesis Planet disintegrates.

Stardate 2/2206.27

The *Bird of Prey* lands on Vulcan. Spock's intellect is restored by transfer of his *essence*, which Spock placed in McCoy just before exposing himself to the radiation that killed him.

STAR TREK TERMINOLOGY

These entries are additions to the Star Trek Terminology section of ST:RPG2. Officers are urged to insert this material into their Sourcebooks for ready reference.

GENESIS DEVICE

The result of a top-secret UFP scientific project, the Genesis Device was intended, literally, to produce life from lifelessness.

When activated, the Device produces radiation unlike any previously known. This radiation, called the Genesis Wave, is believed to be in phase with the basic structure of living things. When the proper radiation level is reached, the Wave begins to alter surrounding matter.

In theory, the Effect would do two things: 1) it would form organic molecules and create primitive life forms up to and including vegetation, but not including animal life, and 2) it would prepare the target world's surface to support carbon-based life. It would, in effect, create a Class M world, with its surface terraformed and reshaped, with its elements restructured to produce a life-supporting environment. If activated in the presence of existing life forms, these forms would be destroyed and the atoms restructured to fit the new life-matrix produced by the Effect. These effects were supposed to range over the entire surface of a target world in a few minutes.

Dr. Carol Marcus and her scientist son Dr. David Marcus, the discoverers of the Genesis Wave, are not totally certain of its nature. It can travel for virtually limitless distances over and through matter, even extremely thinly-dispersed gas, though it does not travel well through vacuum. The Device builds the Wave to a critical level in about 4 minutes, when it begins to affect the matter near it. This instantaneous reaction is referred to as *detonation*. Indeed, the result is more destructive to surrounding matter than any explosion, though the effect is certainly not an explosion at all. Once

the Device is activated, the Wave continues to build to detonation – the Effect cannot be halted in any manner, even by destruction of the Device itself.

The device itself was incorporated into a transparent/translucent torpedo-shaped casing. The casing protects the delicate mechanisms from radiation, temperature extremes, and other adverse conditions. When used, the Device was to be launched from a specially-designed mechanism carried in the shuttle bay.

The only controlled test took place using a test Device thousands of times less powerful than the final prototype was to be. It was activated in a hollowed-out asteroid on the fringes of the Mutara Nebula. The results included the formation of an oxygen atmosphere, fresh water, and microscopic plant life in a few minutes. A full ecological spectrum of plant life formed later, with a substantially accelerated growth rate. The Effect produced climatic and geological conditions that would support the new ecology indefinitely. A full-scale test was to take place on an absolutely lifeless world on which pre-life organic-type molecules did not exist.

The only full-scale prototype was activated by Khan Noonian Singh in a dying attempt to destroy the *USS Enterprise*. Rather than being launched to a planetary surface, the device was set off within the confines of the *USS Reliant*, while deep in the Mutara Nebula itself; the *USS Reliant*, attached to the Genesis Project, was searching for such a world when the ship was boarded and taken over by Khan. The results of the detonation, occurring under conditions not corresponding to the Device's design parameters, were more spectacular and wide-ranging than the Drs. Marcus had expected.

The Effect travelled at light-speed through the thinly dispersed gas that made up the Nebula itself, creating a life-bearing world from an area far greater than the Device was designed to affect. That the Effect produced desired results despite the unfavorable conditions of the detonation came as a surprise even to the Drs. Marcus. What effect the full-scale Device might have produced under design conditions is unknown.

The stability of the Genesis Effect, and of the life-bearing worlds created by it, was only temporary. Instability demonstrated itself on the Genesis Planet within 24 hours after reshaping. Rapid uncontrolled growth of plant life and erratic climate changes occurred, eventually leading to earth tremors, volcanic action, and finally the complete destruction of the planet. Upon examination of the instability, Dr. David Marcus concluded the use of protomatter in the device, the only way to balance the complex genesis effect equation, was at fault. The smaller test area, the Genesis cave on Regula, did not exhibit instability. Apparently, the instability is much slower to develop when the Effect is used on a smaller mass, taking years rather than days to build up.

The death of Genesis co-developer Dr. David Marcus, and the failure of the prototype to produce stable results, make it highly unlikely that this line of research will be pursued further by the UFP in the near future.

PREFIX CODE

As of Reference Stardate 2/1209, all Star Fleet starships have a special coded sequence built into their command console computers. If entered from outside the vessel, this code will allow the control systems to be operated by remote control. The prefix code usually is used only in an emergency.

The command console prefix code is a relatively new innovation, being first installed in *Reliant* Class ships. The older *Constitution* and *Anton* Class cruisers did not contain this system, although all older ships still in service have been retrofitted to include it.

Prefix codes are normally registered with Star Fleet Operations. Code changes must either be requested by or reported to Star Fleet Operations, which must authorize all changes.

Use Of The Prefix Code

If a ship's crew were to be totally disabled, but the ship herself was still intact, the ship's console could be controlled by another ship and brought back under her own power. This has the advantage of not draining the towing ship's power through the use of the tractor beams.

In the movie *Star Trek II, The Wrath of Khan*, Adm. Kirk uses the command console prefix code to override the *Reliant's* console and lower her shields. This was a very useful tactic, but it would not work in a more usual situation. If a Federation ship were fighting a Klingon or Romulan ship, the enemy would not know its command code. Furthermore, if a number of Federation ships were engaged in war maneuvers, their codes would be changed so this tactic would not work if a ship's crew were captured.

REFERENCE STARDATE

Because the Stardates used in the TV series are not in sequence, they are not useful for showing how long it has been since Captain Pike commanded the *Enterprise*, for instance. All new FASA products will use a system of Reference Stardates to measure the absolute passage of time in the *STAR TREK* universe. They will pass at a regular rate, as measured from the communications beacon at the center of Federation space. They will form a sort of 'Greenwich Mean Time' for the events important to *STAR TREK* 'history,' and FASA will use them in placing events in the timeline they develop for their adventures and supplements.

The numbering system for Reference Stardates is the same as that given above, with one exception. A number followed by a slash will always precede the standard Stardate to show the century. The Reference Stardating system will begin with 0/0001.01 meaning January 1,2000. Thus, 1/0001.01 is exactly 100 years later (January 1 2100), and -1/0001.01 is exactly 100 years earlier (January 1, 1900). The Reference Stardate for July 4, 1776, is -3/7607.04, and so on.

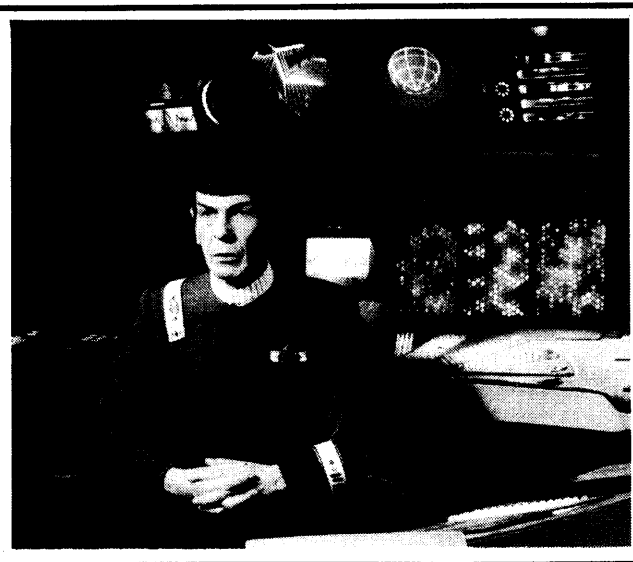

GOVERNMENTS

KLINGON EMPIRE

From Reference Stardate 2/1100 to 2/2200, internal political winds shifted in the Klingon Empire, consolidating the control of the Imperial Race. Until about Reference Stardate 2/1200, much of the interaction between the Federation and the Empire involved a strain of the Klingon race genetically engineered to deal with Humans. Human-fusion Klingons could more easily interact with Humans (and fight Humans) because they were more like Humans. After Reference Stardate 2/1200, less was seen of Human-fusion Klingons along the Federation borders, with the dominant Imperial Race taking a direct hand.

The Imperial Race Klingons, who have less-Human-like features dominated by a protective bony ridge over the forehead, consolidated Imperial power along the borders. The Klingon/Romulan technological exchange treaties increased the Empire's danger to the UFP, with Romulan design concepts being adapted by Klingon shipbuilders. This led to the Klingons' use of ships combining the best of both technologies by Reference Stardate 2/2205, and possibly earlier.

Useful mineral deposits were discovered in the area of space known as The Triangle, where Federation space, Klingon space, and Romulan space intersect. This threatened the small portion of Klingon/Federation border beyond the Orion colonies which lies outside the Organian Treaty Zone. Klingon patrols increased in this area were more aggressive. Evidence was found of careful, tentative Klingon incursions into Federation space itself. These culminated in a secret Klingon scouting mission that led to the infamous Genesis Incident, which resulted in the destruction of the *USS Enterprise*, the capture of an intact Klingon/Romulan ship of advanced design, and the destruction of the Genesis World.

The Klingon Empire has denied all responsibility for the mission deep in UFP territory, claiming that the late Captain Kruge and his crew were acting as independent privateers, a disclaimer typical of Klingon diplomacy. The UFP is now on guard against such deep-probe spy missions using Romulan-design cloaking devices, though it is expected that the failure of the Genesis mission will deter such Klingon efforts for a while.



ROMULAN STAR EMPIRE

The internal political structure of the Empire flourished during the period from Reference Stardate 2/0902 through 2/2200, with no sign of disruptive power struggles. The Empire appeared to be better managed than ever before. During this period of stability, the Romulans made no real threatening gestures along the Neutral Zone, but many experts say that silence, in this case, is more of a threat than noise.

As of Reference Stardate 2/2200, the Star Empire got the best of the continuing series of Romulan/Klingon technological exchanges, at least in the short run. With the question of their Klingon border settled, and with their access to Klingon warp drive technology, the Romulans nearly doubled their fleet size, adding larger and more powerful and flexible starships. They refined and improved their plasma weapon and cloaking device technology, and they adopted Klingon-design photon torpedoes and advanced disruptors. After Reference Stardate 2/2200, the Romulans began showing a tendency to depend less on borrowed technology, and more on their own developments.

GORN ALLIANCE

Relations between the UFP and the Gorn Alliance grew less tense between Reference Stardates 2/1100 and 2/2200, but the improvement was a matter of degree only. The two governments continued to eye each other warily across the conference table at Clanhaven during the all-too-infrequent UFP/Gorn diplomatic meetings, and Gorn warships still patrolled their borders vigilantly.

One of the major stumbling blocks to more normalized relations with the Gorn was the proliferation of militant Gorn factions, who would rather fight the Federation than sign treaties with it. The less-militant factions maintained their hold on the government through Reference Stardate 2/2200, but Federation experts warned that a change could come at any time, with little warning. The workings of Gorn internal politics are not subtle.

This lack of subtlety is not evidenced in the complex Gorn system of debts, obligations, and personal honor. UFP diplomats have noted that Gorn traditions regarding honor-debts "make feudal Japan look like an anarchy." The complicated traditions hampered diplomatic efforts by making it almost impossible not to make some sort of gaffe when negotiating. The system did, however, work in the UFP's favor on occasion, preventing the Gorn from abandoning the conference table altogether.

As of Reference Stardate 2/2200, the Gorn borders remained closed to UFP traffic. Complicating matters was the fact that various Gorn factions claim different borders. Some independent trade, mostly registered out of the Orion colonies, continued to go in and out of Gorn space. It is well-known that Orion interests continue to trade with the Gorn militarists. It is believed that some of these efforts are Klingon-controlled, or at least Klingon-inspired.

ORION COLONIES

During the period from Reference Stardate 2/1100 to 2/2200, the Orion Colonies officially remained friendly to the UFP as associate members of the Federation and neutral to the Klingons. Orions continued to trade with both governments, but they were supposed to trade no UFP-obtained goods directly with the Klingons. On a practical level, it proved impossible to adequately police such a prohibition. On some of the more anarchistic tradeworlds, Klingon and

Federation merchant crews alike could go into the same shops and buy their choice of Klingon hand disruptors and Federation phasers, or any other goods.

Piracy continued to irritate the sensitive interface between the Klingon Empire and the UFP. Pirates based in this area continued to prey on shipping. Some piracy is believed to have been caused by Klingons, who tried to blame their activities on Orion pirates; cynics remarked that this was only fair, because the Orion pirates had been blaming their raids on Klingons for twenty years.

Though the Orion Colonies gained associate UFP membership and favored trade status was conditional upon abolition of the green slave trade (leading to the Orion Abolition Crisis), the policing of these laws remained the responsibility of UFP forces. Orion police agencies continued to ignore green slavery, at least on a small level, taking action against major violations only when prodded to do so by threats of trade restrictions and armed Federation intervention.

THOLIAN ASSEMBLY

As of Reference Stardate 2/2200, the UFP was no closer to normalizing, or even establishing, relations with the Tholian Assembly than ever before. The Tholians remained belligerent inside their closely-guarded area of space and steadfastly refused all efforts at peaceful contact. They ignored UFP invitations to exchange envoys or information, and guarded their borders jealously.

Little new knowledge about the race has been gained, with information from the infrequent encounters often being contradictory. Evidence pointing to the Tholians being a crystalline race seems to be borne out by their ships, which seem to be made of some sort of crystal, perhaps grown rather than built. The ships observed exhibit variations of the basic wedge design, but reports about the performance of these ships varied widely.

The Tholian Assembly has not wavered in its border claims since first contact, nor have the Tholians wavered in challenging any ship that even appeared to be on a course into Tholian-claimed area. Because several major trade routes formed near this area during the period, border incidents were more frequent, and were harder to smooth over when they occurred. Unknown, unseen, they remained the greatest mystery in UFP diplomatic history.

UNITED FEDERATION OF PLANETS

Between Reference Stardates 2/1100 and 2/2200, the UFP grew as its non-interference policies and economic freedoms bore fruit. As of Reference Stardate 2/2200.01, the UFP had more than 500 full-member worlds, as well as a large number of associate members, protectorates, and allied star systems.

This growth gave the Federation a broad and strong economic base. Though costs for Federation services increased with demand, the Federation remained financially stable. Much of the economic success in this period was due to the phenomenal success enjoyed by UFP-supported scientific research, which added revenues through the licensing of new processes to private corporations. Only a few projects, notably the multitronic computer and the Genesis Project, were total failures.

During this period, much of the UFP's excess funding was earmarked to expand and update Star Fleet. The ever-present threat posed by the Klingon Empire, the Romulan Star Empire, and such minor powers as the Gorn Alliance made defense spending a necessity. Even so, such Star Fleet leaders as Admiral James T. Kirk, hero of the V'ger incident, kept exploration efforts in step with necessary military expansion.

STAR FLEET COMMAND

UNIFORMS AND INSIGNIA

The following section, dated Reference Stardate 2/1207.01, is a replacement for Section 4.23.7/A, which Officers are directed to remove and replace immediately.

UNIFORMS

The standard uniform for all Star Fleet personnel after Reference Stardate 2/1207.01 is to be the long-sleeved, round-necked tunic in grey or tan, with one-piece pants and foot coverings. The standard belt monitor is to be attached at waist level in front.

INSIGNIA

The ship's insignia of the *USS Enterprise* has been officially adopted as the insignia for all of Star Fleet, and all uniforms worn after Reference Stardate 2/1207.01 will display the new insignia. This insignia consists of an asymmetric arrowhead, with the command star centered upon it, the whole emblazoned overlapping a small circle.

Sleeve stripes will continue to denote rank, but service branch will be denoted by the color of the insignia's background circle, as follows:

BRANCH COLOR FOR UNIFORM INSIGNIA

Branch	Branch Color
Command	White
Science	Orange
Engineering	Red
Medical	Green
Operations	Yellow
Security	Silver

Historical Note: The unique insignia of all ships of the line used prior to this date, with the command, services, sciences, and medical division symbols centered on the ship's insignia, were altered to give honor to the *USS Enterprise* upon its successful return from its five-year mission under Capt. James T. Kirk.

UNIFORMS AND INSIGNIA

The following section, dated Reference Stardate 2/1909.17, is a replacement for Section 4.23.7/A, revised 2/1207.01, which Officers are directed to remove and replace immediately.

UNIFORMS

The standard uniform for all Star Fleet personnel after Reference Stardate 2/1909.17 is to be the long-sleeved, red-maroon, wrap-around tunic with white inner panel, ribbed collar, and ribbed cuffs; a white band is to encircle the left arm three inches above the cuff. Uniform pants are to be black with a color stripe down the right leg. A right shoulder strap edged in thin gold braid is to secure the tunic flap, and a wide black belt with a brass buckle is to be worn over the tunic. Buckle and a smaller brass pin, worn atop a white, oblong tab on the left breast, will prominently display the Star Fleet insignia.

INSIGNIA

All uniforms worn after Reference Stardate 2/1909.17 are to display the new insignia. This insignia consists of a pin on the tunic shoulder strap and on the left sleeve just above the white band. Rank insignia is shown below:

STAR FLEET Rank Insignia



Flag Admiral



Admiral

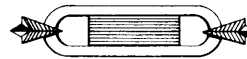

Commodore



Captain

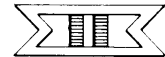

Commander



Lt. Commander



Lieutenant



Lieutenant J.G.



Ensign

The tunic collar and cuffs, and the pant stripe, are all of the new branch color, as follows:

BRANCH COLORS FOR UNIFORMS

Branch	Branch Color
Command	White
Science	Light Blue
Engineering/Helm	Gold
Medical	Green
Operations	Gray
Cadet/Trainee	Red

Historical note: The grey or tan singlet proved to be unpopular with Star Fleet officers and enlisted personnel and with the public. It was altered to the new uniform on Reference Stardate 2/1909.17, at the same time that Star Fleet discontinued the use of the belt monitor.



PERSONAL EQUIPMENT

The following section, dated Reference Stardate 2/2205.01, is a revision for Section 6.82.40/A. Officers are directed to immediately remove and replace updated/revised items, marked ○, and to add new items, marked ■.

■ ARMOR, SECURITY

This armor suit is composed of chest and back plates of plastimetal with a plastimetal fabric-mesh undersuit and topped off by a heavy plastimetal helmet. It is worn by on-duty security personnel aboard ship, and by landing party security officers in potentially hostile situations.

The plastimetal plates are capable of absorbing impact, and the vest is proof against any club and will stop the average bullet. They cannot be cut by conventional weapons, and thus are proof against a knife attack. The undersuit also provides protection against cutting or puncturing weapons, including missile weapons, but not against heavy blows. Continued punishment may abrade the suit's protection.

A fine mesh of iridium alloy is imbedded in the plates and is connected to an energy-damping coil in the suit's belt. This system has the effect of damping out the effects of some energy weapons, including phasers and disruptors, reducing their effectiveness. The suit is *not* proof against the surface-conducted effects of a phaser set on *disintegrate*, or by late-model disruptors set on *high-energy*; such direct hits will still disintegrate the target. It is effective, however, against grazing shots from such settings.

The open-face helmet is not intended to protect against gas, bioagents, or vacuum; a life support belt may be worn over the suit to afford such protection, if needed. It has a built-in communicator that matches the specifications of the standard Star Fleet wrist model.

Some versions of the suit have a life functions monitor panel (similar to a *Belt Monitor* built into the front of the chestplate. The monitor can be tied in with a ship's computer to activate security alarms if a guard's life functions alter drastically. (Phaser stun and similar effects do not affect life functions drastically, but being physically knocked unconscious or killed would.)

It takes about 1 minute for trained security personnel to put on a suit, and longer for untrained man personnel. Because all suits are tailor-made for the wearer, only a person's own suit will fit him. Helmets are interchangeable and do not require special fitting except for Andorians, because of special antenna protection. Security personnel on call for intruder alerts and the like wear their suits but not their helmets.

Replacement suits can be run up in 10 minutes by a ship's material fabrication unit, if the pattern records are available. Measurements for a new fitting take about 2 hours by hand, but only 15 minutes by special fitting scanners available aboard larger ships.

Technical Data

AP Cost For Use: Characters with a Skill Rating of 10 or more in *Security Procedures* are trained in the use of the suit. Untrained characters who wear the suits lose 1 AP per turn.

Untrained persons will take a minimum of 2 minutes to don the armor. At the end of 2 minutes, a Saving Roll against the DEX score is made. Failure requires an additional minute and another DEX save attempt, with a modifier of +5. Additional attempts may be made each following minute until successful.

Helmets require only 1 AP to put on, but 3 more AP to hook up and adjust the built-in communications gear before it can be used.

Protection From Physical Blows: If the wearer is hit with clubs, swords, projectiles, etc., the gamemaster must determine the hit location, the damage absorbed, and the reduction in the suit's protective value.

To determine if the hit was on the heavy vest and helmet material or on the lighter fabric, roll 1D10; a roll of 6 or less means the hit was on the heavy material.

Damage from a hit on helmet or vest is reduced 25 points. Damage from hits on fabric are reduced 25 points if from projectiles like bullets or from weapons that work mostly by cutting or puncturing (like knives or swords), but there is no protection offered against the crushing effects of blows from clubs, heavy axes, etc.

Protection From Energy Attacks: The suit's energy-damping coil will absorb up to 25 points from attacks with phasers, disruptors, or similar weapons on stun or disrupt settings. The special plastimetal plates and fabric is totally impervious to old-style hand lasers, though heavier laser-type weaponry would do half damage.

Blows To Head: A physical blow to the helmet of greater than 10 damage points requires the player to make a LUC Saving Roll. If the roll fails, the helmet communicator is damaged and will not function. If the suit's helmet is off, a direct, aimed hit or an accidental hit (10% chance on every attack) to the head will do full damage.

Damage To Suit: The suit's protection is broken down under repeated attack by physical weapons but not by energy weapons. The suit has a protective value (against both energy and physical weapons) of 12 points per attack after it has absorbed 50 damage points, and it gives no protection after it has absorbed 50 more points.

Restrictions On Use: The suit is designed for maximum comfort and minimum restriction; a character may sit or even lie down in armor, but cannot sleep in it.

■ BELT MONITOR

This device, in service Reference Stardates 2/1207 through 2/1909, monitored the life signs of the wearer in a manner similar to that of a medical Feinberger. The use of the system on Star Fleet issue uniforms was discontinued mainly because it did not prove to be worth the trouble of maintaining it. Landing party life signs could be monitored by tricorder quite easily, and, in practice, Medical Officers rarely were satisfied with the limited data available through the buckle monitor. In addition, the shipboard monitor system was very complex and used up far too much computer time for the relatively small amount of useful data it produced.

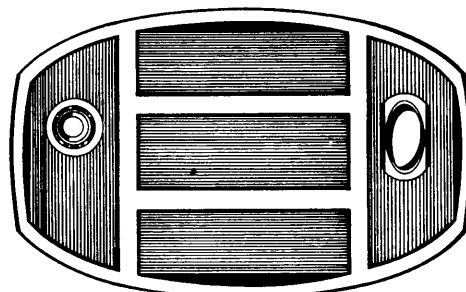

Data from the monitor could be read by touching a small control on the buckle and examining a readout panel under a small flap on the device. Because the belt monitor was also equipped with a very short-range data transmitter, which could be monitored by ship-based medical computers from Sick Bay. Location of the wearer could not be determined, however, since the system picked up signals through induction in the ship's intercom system wiring. Each buckle's data signal was coded. Thus, a Medical Officer could check the basic life signs of a specific crewman without calling the crewman in for a checkup. A standard communicator near the subject (within 1.5 meters) could also pick up the signal for relay, thus making it possible to easily monitor the life signs of a landing party.

Dr. Leonard McCoy (Cmdr./Chief Medical Officer, *USS Enterprise*) delivered the death blow to the system in his deposition to Star Fleet Medical Corps Department Of Equipment Evaluation. He cited the above problems, but also declared that "the system also gives starship crewpersons – already stubborn enough – yet one more excuse for missing their periodic physical examinations. Personally, I learn as much from seeing a patient as I do from his readings. I can do without instant feedback on such a limited basis, but I can't do without the personal contact that is an important part of the examination process."

Based largely on McCoy's recommendations, the system's use was discontinued on a Fleet-wide basis. Such monitors are available to medical personnel (in wrist- or buckle-mounted versions) for special applications, but are no longer a part of standard-issue uniforms.

○ COMMUNICATOR

There are two basic types of communicator in use in Star Fleet. One is a light-weight wrist communicator, and the other is a palm-size voice transmitter/receiver with a flip-up antenna grid, used by Federation Star Fleet personnel on landing parties. Several channels are available on a Federation communicator, and the user can select which other communicators to call. If a communicator is signaled, it beeps for attention. Though most frequently used for voice communication, the communicator also can trigger a homing signal, and so it serves as a locating device for operation of the transporter. It can be attached to portable data-gathering instruments, allowing them to transmit data to the ship's computers.



The maximum range of the standard flip-grid communicator is about 32,000 km (20,000 mi), an improvement over older units in service prior to Reference Stardate 2/1303. The wrist communicator is serviceable over shorter distances, up to 8,000 km (5,000 mi). Both types can be used

on a planet's surface over line-of-sight distances, or to contact a ship in standard orbit. The signal may be blocked by atmospheric disturbance, by intervening terrain (like mountains), or by dense materials (like ore deposits).

There are several models of flip-grid communicator in service with Star Fleet at this time. One is a small black box with a gold antenna grid, often used on diplomatic missions or other occasions when the user is in contact with the public. This communicator is concealable under the tunic. Another common model is larger, with a silvery finish and grid and a bar-shaped light at the bottom which glows during operation. This model is more rugged than the smaller type, and is most often used on survey parties. Flip-type communicators are only active when the grid is up. They usually are not used aboard ship because strategically placed communications panels are more convenient.

The wrist communicator has most of the same capabilities as the flip-type communicator, but it has a substantially reduced range and is a bit less reliable under adverse conditions. The wrist communicator has one feature not possessed by flip-grid communicators: it can be left on, actively receiving and transmitting sound for an extended period to monitor a landing party's progress. Used for communication over shorter distances than the more elaborate flip-grid communicators, it is capable of handling communications with a nearby ship or within a ship, but is rarely used for landing parties unless one or more flip-type communicators is also available to act as a local relay. It can also be used for ground-to-orbit communication when orbital booster stations are present (such as around most developed UFP worlds), or where a stronger ground-based transceiver (such as that in a shuttlecraft) can be used as a relay. The wrist communicator also can be attached to an environmental suit, using the suit's built-in power supply to boost the communicator's signal strength to that of the flip-grid variety.

Most starfaring cultures use similar devices. The Klingon version, which has been slightly altered by the Romulans, combines some of the functions of the Federation communicator and the Tricorder, in that it is capable of scanning for nearby energy sources.

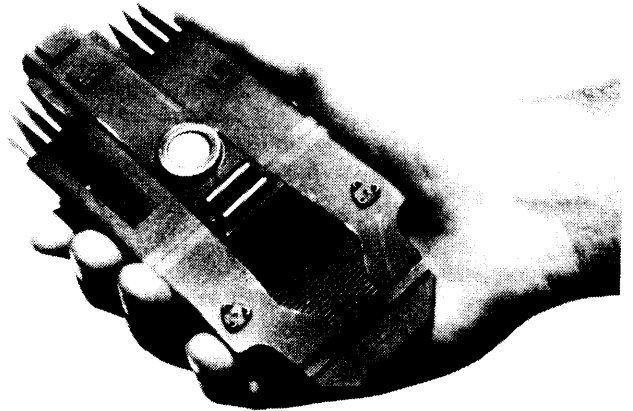

Flip-grid communicators are fairly rugged. A strong shock, such as a sharp blow or a fall to the ground, has only a 10% chance to disable the standard black-box model and only a 5% chance to disable the tougher silver-box, heavy-duty model.

The wrist communicator is more delicate. A strong shock has a 20% chance of causing the communicator to fail. Also, its less powerful circuitry requires the application of a 10-point penalty for any Saving Rolls made when communicating through adverse conditions.

○ ENVIRONMENTAL SUIT

This suit, sometimes called a 'space suit,' is used where maximum protection is required. It maintains a self-contained, artificial environment, providing air, temperature, and pressure regulation. The suit is safe for deep-space vacuum, for otherwise unlivable heat or cold, or for poisonous atmospheres. Models in use since Reference Stardate 2/1209 can maintain their artificial environment for 36 hours, an improvement over earlier models.

The improved models no longer have helmets that are transparent 360° around. The helmet is opaque to the back and around part of the side to afford shade against harsh sunlight. The front transparent portion now darkens automatically to protect against flash effects. A wrist communicator, attached to this suit, can use the suit's built-in power-pack to boost its signal range.

The environmental suit is not particularly uncomfortable, but it is a bit bulky. The suit is self-sealing; though it would be difficult to tear, a standard spray hypo can be used right through the sleeve. The improved model is more resistant to damage, though it is still no protection against modern energy weapons, or even against most impact, projectile, or cutting weapons.

Use of the suit in either version requires training, and unskilled persons should not attempt to perform any but the most simple tasks. Persons with minimal proficiency in *Environmental Suit Operation* can perform normal tasks. Success at unusual tasks that require manual dexterity, or in such strenuous actions as running, jumping, or fighting depends on the skill of the individual in such operations.

Klingons, Romulans, and other starfaring cultures have similar suits.

■ RADIATION-SHIELDED SUIT

This bulky white garment covers the body entirely up to the neck, and is now worn by all starship Engineering personnel when on active duty in areas where radiation leakage is a possibility. The suit prevents the slow buildup of radiation poisoning that could otherwise occur with cumulative exposures over a long period of time. For occasions when radiation is an immediate hazard, a special helmet can be fitted to the suit.

The suit contains a small compressed air supply. The need for this feature grew out of the continual poison hazard from coolant leaks in phaser systems and warp drive power units. The suit's air can be tapped by plugging in a small disposable breathing mask on occasions where the wearer does not wish to be hampered by donning the helmet; supplies of these masks are kept on racks in all areas where poisonous coolants are stored, ducted, or used.

The suit is not meant to protect against major radiation leaks. Most starships have energized transparent barriers with rotating airlocks that are lowered into place to close off contaminated areas. To work in these areas, special radiation armor is needed. Such armor fits over the radiation suits.

Technical Data

It takes about 3 minutes to don a radiation suit, including gloves and boots. It costs 6 AP to don a radiation helmet or 2 AP to attach a breathing mask. Adding heavy radiation armor adds another 5 full minutes to the total.



Radiation Shielded Suit

■ TRICORDER, ADVANCED MODELS

Standard Sciences Tricorder

For most uses, the standard sciences tricorder is still in use, though the sensitivity has been improved to increase its range. Several variations are in service, including a light-duty model mostly for shipboard or indoor use.

Energy Sources: General energy source scans may be made at ranges of 1200 meters, with specialized scans at ranges of 175 meters.

Physical Composition: General scans for concentrations of a desired substance can be made at ranges of 1200 meters. Specialized scans for detecting the primary composition of an unknown object can be made at ranges of 175 meters.

Life Forms: General life-form scanning range has been improved to 700 meters, with individual life readings and general life-form type distinguishable at 150 meters.

Directional Sciences Tricorder

A sciences tricorder has been developed with greater directional control and range than the standard tricorder. Sometimes issued by Star Fleet, this tricorder resembles a weapon (a disadvantage in the eyes of some), with a pistol-like appearance and a pistol grip. The controls, readouts and view-screen are located in a recessed niche on top. They are even more sophisticated than the older model. Sensors and data pickups for visual and audio are located in the tapered directional nose of the device. Other audiovisual pickups on the top surface focus on the user for note-taking during scans. There is a slot to accept either standard tricorder disc packs or data carts of any type.

When not in use, the directional tricorder hangs on a lanyard at the user's belt. The lanyard has a magnadhesion clip that can be attached to appropriate strips on most Star Fleet uniforms.

Though the directional tricorder makes the same types of scans as the standard model sciences tricorder, its sensitivity gives it greater range. Because of the directional nature of this model, any particular scan requires about 10 seconds to complete, and it covers only about 45° of arc. Thus, it would take 80 seconds to make a complete 360° sweep. The model's limited arc is felt to be a serious disadvantage.

Energy Sources: General energy source scans may be made at ranges of 1500 meters, with specialized scans at ranges of 200 meters.

Physical Composition: General scans for concentrations of a desired substance can be made at ranges of 1500 meters. Specialized scans for detecting the primary composition of an unknown object can be made at ranges of 200 meters.

Life Forms: The model's major improvements are in life-form detection. General life-form scanning range has been improved to 1000 meters, with individual readings and general type distinguishable at 250 meters.

Standard Medical Tricorder

Sensitivity and range of the standard medical tricorder has also been improved, though it retains its basic outward appearance. There are several variants of this model being issued, but all have basically the same characteristics.

Chemical Composition: General data on presence of a substance, including its direction and distance, now can be determined at 150 meters. Exact composition of an unknown, as well as its effects on various life forms, now may be determined at 15 meters.

Life Forms: The life forms scan now can identify a known life form and give biological data within 25 meters. Medical data now may be read at 3 meters.

Klingon Tricorder

The Klingon Imperial Fleet now issues a tricorder-type device to its personnel. This unit has an inner mechanism and abilities so similar to the older Star Fleet sciences tricorder that it is almost certainly a copy of a captured design.



New Standard Tricorder (front view)

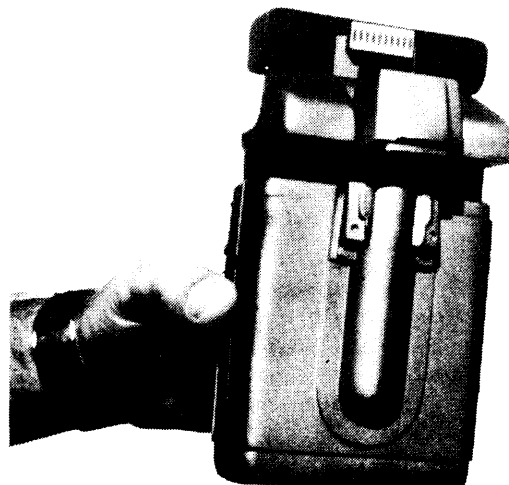

New Standard Tricorder (rear View)

Klingon Tricorder

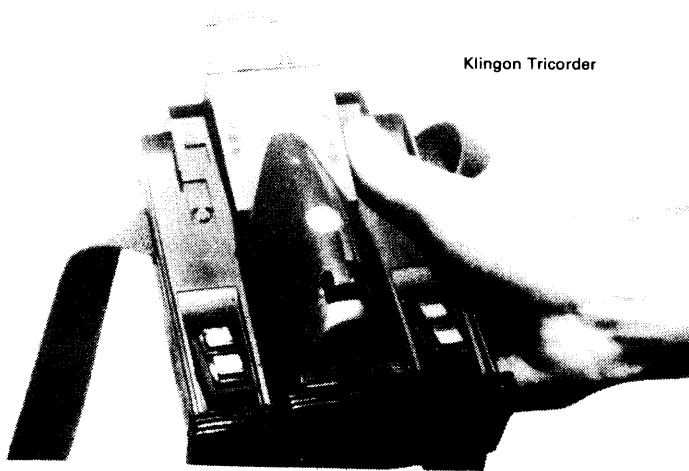

TABLE OF TRICORDER ABILITIES AND RANGES

Scan	Type	Information Obtained	Ranges		
			Directional	Standard, improved	Standard
<i>For Sciences Tricorder:</i>					
Energy sources	General	Direction, distance	1500	1200	1000
	Specific	Identification of type	200	175	100
Physical Composition	General	Direction, distance	1500	1200	1000
	Specific	General composition	200	175	100
	Determinative	Complete chemical composition	15	15	1.5
Life Forms	General	Presence	1000	700	500
	Specific	Number and type	250	150	100
<i>For Medical Tricorder:</i>					
Chemical Composition	General	Presence; Direction, distance		150	100
	Specific	Exact chemical composition; Effects		15	1.5
Life Forms	General	Biological data		25	
	Specific	Diagnostic medical data		10	1.5

SIDEARMS

The following section, dated Reference Stardate 2/2205.01, is a revision for Section 6.82.40/A. Officers are directed to immediately remove and replace updated/revise items, marked ○, and to add new items, marked ■.

FEDERATION STAR FLEET

Phaser A sidearms largely have been replaced by the newer and more powerful Phaser B model. Phaser B weapons remain modular, but their controls have been simplified for easier setting. The improved phaser design is not in widespread use outside Star Fleet. Some Star Fleet vessels, particularly support ships in non-contested areas, are still equipped with Phaser A models. In almost all cases, privately ownedphasers would be of the original variety.

Star Fleet policies on issuing phaser weapons (except phaser rifles) have somewhat relaxed, particularly in areas where hostilities have occurred in the past. This is true of ships patrolling the Romulan and Klingon borders.

■ Phaser I-B

Phaser I-B is palm-sized and concealable. With the simplified controls, resetting for stun, heat, disrupt, or disintegrate no longer requires moving a thumbwheel. The improved model has touch-sensitive, fingertip-sized panels that are color-coded for all function settings. Thus, resetting functions requires only a quick motion and thus little attention from an experienced operator. Resetting for wide-angle stun or heavy stun shots requires a separate adjustment.

Phaser I-B does slightly more damage on all settings but heat. Its power increase, however, has given it greater effective ranges. The table below gives these new ranges and damages.

Pressing all four color-coded buttons at once activates the overload feature. This model emits an electronic whine, rising in pitch, for 60 seconds, then explodes, giving damage to anything within a radius of 45 meters. Pushing all four buttons simultaneously is a deliberate action that is almost impossible to do accidentally. Nevertheless, the phaser's on/off button deactivates overload if pressed within the first 10 seconds.

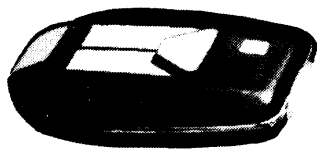

Several firms bid for the contract, and so the styling is different. The original phaser supplier has kept the same basic styling for the Phaser I-B model, with some minor changes to accommodate the new-type control systems; some of these models have been sold to the general public. The other manufacturer supplies his version of the Phaser-I-B in a sleeker blue-gray housing; these are manufactured under exclusive contract to Star Fleet and are not available to the general public. Both are still in use in Star Fleet, but the contract will probably be eventually awarded to the first supplier, as the blue-grayphasers are somewhat larger, and have no real advantages over the more familiar design.

■ Phaser II-B

The Phaser I-B, like the previous model, snaps into a pistol-grip mount which gives it greater accuracy and a larger power-pack. The connections between Phaser I-B and Phaser II-B differ from the connections between the A models; furthermore, they are different for each of the new-model styles.

Because they are not interchangeable, the Phaser I component of one style cannot be used with the Phaser II pistol mount of another style. The sole exception is the charging jack for the phaser power-packs, which is the same on all three units and requires no adaptors.

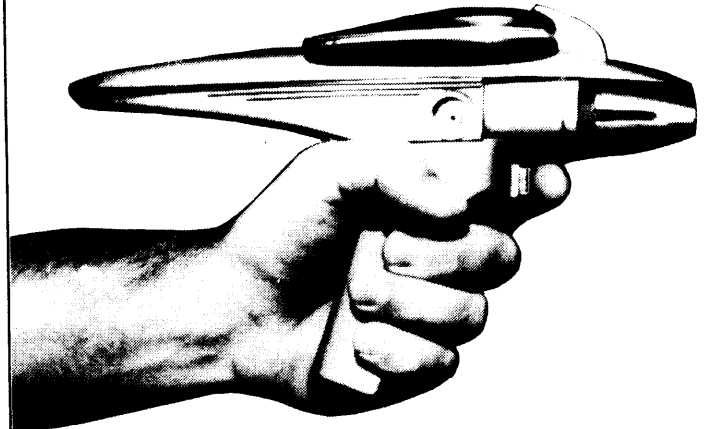

■ Phaser Rifle

The phaser rifle has not seen improvement, and it is still in widespread use in the Military Operations Command and Marine Corps Command. Star Fleet rarely issues rifle-type weapons for use by anyone other than ground combat forces. A forearm rest is being tested with a power booster, and may be adopted by Star Fleet in the future, but it is still too unreliable for general use.

Because of the new simplified setting system, changing settings on the improved phaser designs now costs only 1 AP for anyone familiar with its use. A Skill Rating of 20 in *Modern Marksmanship* qualifies a user as sufficiently familiar for the lower AP cost, but only if a phaser is a standard hand weapon for that character to use. A Federation citizen, even a civilian, with the proper level of skill could qualify, but a Klingon could not. Marginal cases are left to gamemaster discretion.

The quick-reset feature of the improved phaser designs applies only to standard stun, heat, disrupt, or disintegrate settings, each of which has a color-coded button. Resetting for heavy stun or wide-angle stun requires the use of other controls as well, and still costs 2 AP to accomplish.

KLINGON EMPIRE

○ Mark I Hand Disruptor

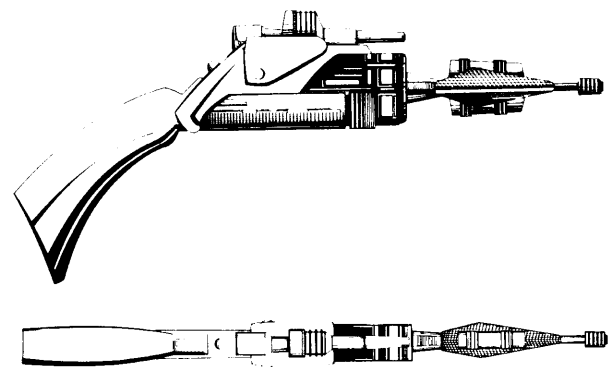

The disruptor sidearm works on the principle of cellular disruption, affecting the delicate nerve cells of a victim. A grazing shot will produce first pain, then numbness of the extremity hit. A direct hit continues to produce damage through actual heating of the tissues, but does not disintegrate the target. Prolonged exposure will produce vibration

and heat in any solid matter, eventually shattering, melting, or burning it.

The Mark I hand disruptor (and all other models) uses the unique grip-and-firing-stud design of Klingon armsmiths instead of the more familiar trigger. All four fingers of the hand are curled under the grip, with the thumb resting atop the firing stud for activation.

The Mark I hand disruptor is the Klingon sidearms traded to the Romulans, the Orions, and others. It is often found on the black market even within the Federation.

The Mark I hand disruptor is somewhat clumsy to use and hard to field-repair. The beam exciter cylinder at the base of the barrel must be shielded by small field grids mounted on either side to keep the beam properly focussed. If the weapon is dropped or handled roughly, these grids may be misaligned, resulting in less accuracy.

Technical Data: A character should be required to make a Saving Roll against his LUC score when first attempting to use a dropped or struck Mark I disruptor. Failure means the grids are misaligned. Weapons with misaligned grids fire at all targets as if they were one range class farther away. Thus, a short-range shot would have the range modifier for a medium-range shot, and a medium-range shot would have the range modifier of a long-range shot. An extreme-range shot would not hit with a damaged disruptor. Grids may be realigned with a small tool kit and a successful Skill Roll against the rating in *Personal Weapons Technology*. The repair takes about five minutes.

○ Mark I Disruptor Rifle

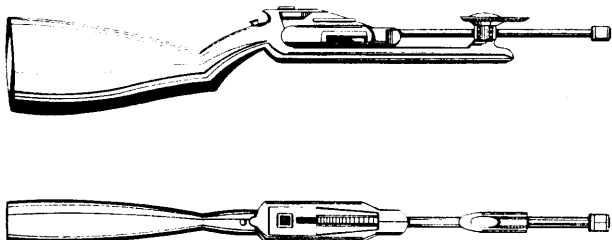

A heavy-duty version of the Mark I hand disruptor, the disruptor rifle has identical effects but a greater range and a larger power-pack. It is used mostly by ground troops, security forces, and guards on active duty. Its advanced focussing method eventually led to the improved Mark II pistol. It is tough enough to use as a parrying weapon without sustaining much damage. This weapon is also widely used, in somewhat varying forms, among other rivals of the Federation, notably the Romulans.

○ Mark II Hand Disruptor

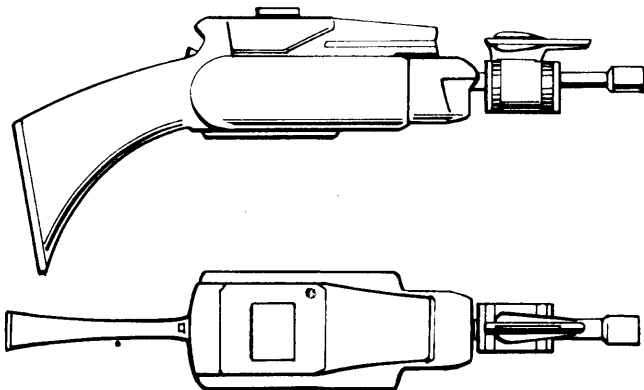

The Mark II came into use about Reference Stardate 2/0901 and was the first hand disruptor to feature the molecular debonding effect. At the standard setting, the Mark II has marginally better performance than the Mark I. At the extreme power setting, however, it is capable of disintegrating a man-size target, though this setting is extremely wasteful of power and is not effective at extreme range. Power adjustment for the Mark II is accomplished by turning the front ring of the beam exciter cylinder at the base of the barrel. The Mark II does not require the field grids used on the Mark I, and hence is not as delicate. There is not rifle version.

■ Mark III Hand Disruptor

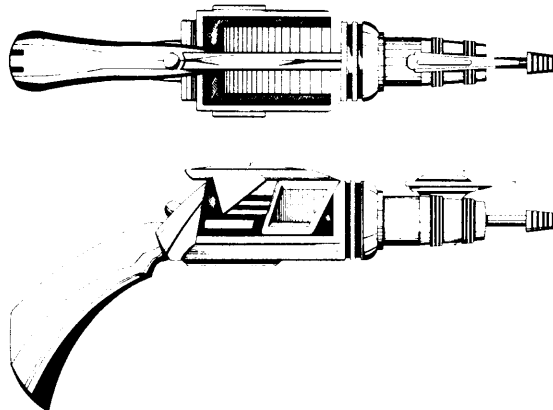

The Mark III hand disruptor came into use about Reference Stardate 2/1901. It has a greater range and power reserve than the Mark II. Though it is somewhat more bulky than the Mark II, it is easier to manufacture and repair. Like the Mark II, it can use the molecular debonding effect to disintegrate a man-size target except at extreme range. Several different models of the Mark III are in use, but the differences among them are cosmetic.

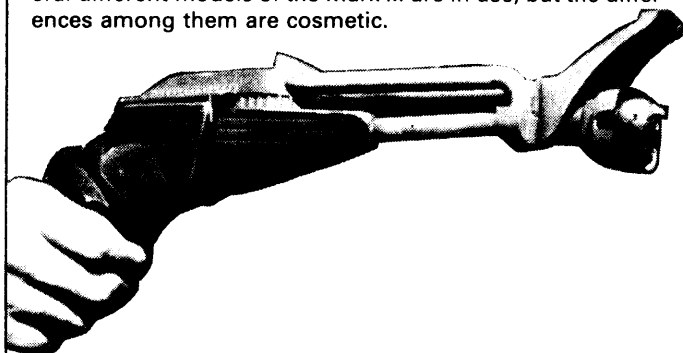

■ Mark III Disruptor Rifle

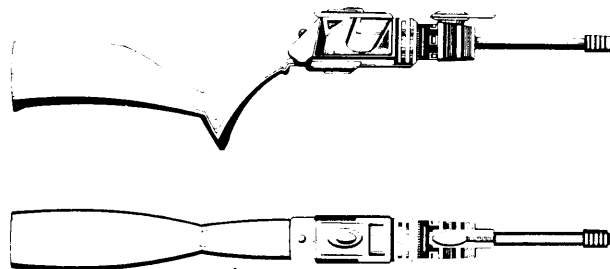

The Mark III disruptor rifle is formed by adding an extension stock and a longer beam-guide barrel. The stock contains a larger power-pack, and the longer barrel gives the weapon greater accuracy.

GORN ALLIANCE

○ Mark I Blaster

As with other elements of Gorn technology, Gorn sidearms are not subtle. The Gorn blaster fires a beam of semi-coherent energy that does damage through burning and cellular disruption. The beam on the blaster is not well focused, and hence the early models have shorter ranges than other hand weapons. Because the blaster is simply a naval sidearm and not a primary combat weapon, the Gorn do not consider this a drawback.

There are a number of individual designs in use, including some used as trade items with other cultures. Military-issue versions of the early blaster were designed for the massive, somewhat clumsy Gorn hand. This type of weapon is clumsy for other races to use, and trade weapons are restyled for smaller hands.

Technical Data: The original Gorn military-issue blaster pistol was designed for the massive Gorn hand. Other, less massive, races trying to use it must apply a 10-point penalty to the To-Hit Number.

■ Mark II Blaster

The Mark II blaster, introduced about Reference Stardate 2/1910, is a bigger and more powerful version of the Mark I, though it is not much more accurate. This model has become widely used by some Gorn units. The military-issue version of this blaster forsakes a standard pistol grip entirely, in favor of a triggering bar that is squeezed. Very few non-Gorn have hands massive enough and a grip strong enough to fire it.

Gorn landing parties carry the blaster sidearm as a matter of course, but Gorn soldiers engaged in active combat are usually more heavily armed.

Technical Data: The newer military-issue blaster is not pistol-shaped at all, and mounts a heavy firing bar requiring more pulling force than the average Human can provide. No character with less than a STR score of 70 can fire the weapon at all by hand. Even those who are strong enough must use both hands, and they must apply a 20-point penalty to the To-Hit Number.

■ Sonic Stunner

The sonic stunner is a heavy, clumsy weapon used by security forces for crowd control. In size and weight, it is similar to a small archaic carbine. It delivers only non-lethal damage, causing its targets to fall unconscious; these effects are similar to Federation phasers set to stun.

SHIPBOARD SYSTEMS

The following section, dated Reference Stardate 2/2205.01, is a revision for Section 6.82.40/A. Officers are directed to immediately remove and replace updated/revised items, marked ○, and to add new items, marked ■.

■ A-GRAV CARRIER

This device allows heavy pieces of cargo to be moved about easily on an anti-gravity cushion. The unit, about the size and general shape of a small life-raft, can carry about 500 kg; several may be connected together. Controls for the unit's anti-gravity lifters are in a small box attached to a collapsible metal rod extending from one end and acting as a steering device. When the unit is in operation, cargo containers sit atop it as it floats at about waist-height. These devices are used wherever heavy items are to be moved, whether aboard ship or in a spaceport.

■ A-GRAV PLATFORM

This floating work platform will raise and lower items to any height, replacing portable ladders and the like for repair and maintenance. It is disc-shaped and about 1 meter across, and it is controlled with a hand-held wireless control box. Standard models will support up to about 200 kg, but heavier-duty models are also in use. These devices are also in use planetside.

■ SECURITY LOCK PANELS

Featured on all new ship designs, these panels are used to seal important security doors by entering a coded sequence electronically by computer or manually by security personnel. The panel consists of a 15-button touch-panel keypad and a status display; the buttons glow green, and the status display glows red and announces "LOCKED" when the door is sealed. Once locked, the door can be opened only by entering the proper sequence of buttons or by computer override.

■ THRUSTER SUIT

The thruster suit is a low-cost, easy-to-use version of the standard environmental suit, developed as a one-shot emergency escape device. The thruster suit is not meant for use in hostile planetary atmospheres but only in vacuum, and it carries only a 10-hour air supply. The main thruster is a simple chemically-fueled rocket with small attitude jets for simple maneuvering. Sophisticated controls are set in an extension arm.

The thruster suit is intended for use by vessels in orbit around a developed, friendly planet, or in other situations where a rescue vessel is nearby. Obviously, they are only used when rescue by transporter or shuttle is not possible. During an 'abandon ship' situation, a person could don a thruster suit, use the attitude jets to point safely away from a crippled vessel, and fire the main thruster. The thruster would carry the escapee away on an easily-traceable course out of danger and into a safe orbit or toward a rescue vessel. The amount of thrust and burn time can be preset with the use of the micro-computer in the extension arm controls. Once the burn is completed, the thruster pack can be discarded.

The thruster pack/control extension arms can also be attached to a standard new-model environmental suit for special purposes. The new model suits are too expensive and bulky, however, to be carried in sufficient quantities for large-scale escape and rescue operations. Availability of thruster suits is currently restricted to larger vessels while the system is field-tested. Eventually, they may be issued to all Star Fleet vessels and likely adopted by private vessels as a last-ditch escape packages.

■ TRANSPORTER, Improved Models

Improved transporter models have been modified so that the paralysis and suspension of time-sense normally associated with transporting is eliminated. It is possible for someone being transported to make limited movements, as long as he remains in the scanning field. It also is possible for those in transit to hear, speak and see while in transit. Though there is a split-second discontinuity, in which the transportee is effectively non-existent except as an energy pattern, this passes too quickly to notice and someone engaged in a conversation would not even notice a gap.

The improved models come as a result of experiments with more powerful designs. These experiments led to the conclusion that more power led inevitably to less safety. The more powerful models were more prone to failure, and this line of research was abandoned in favor of refining the scanning process.

STARSHIP RECOGNITION FILE

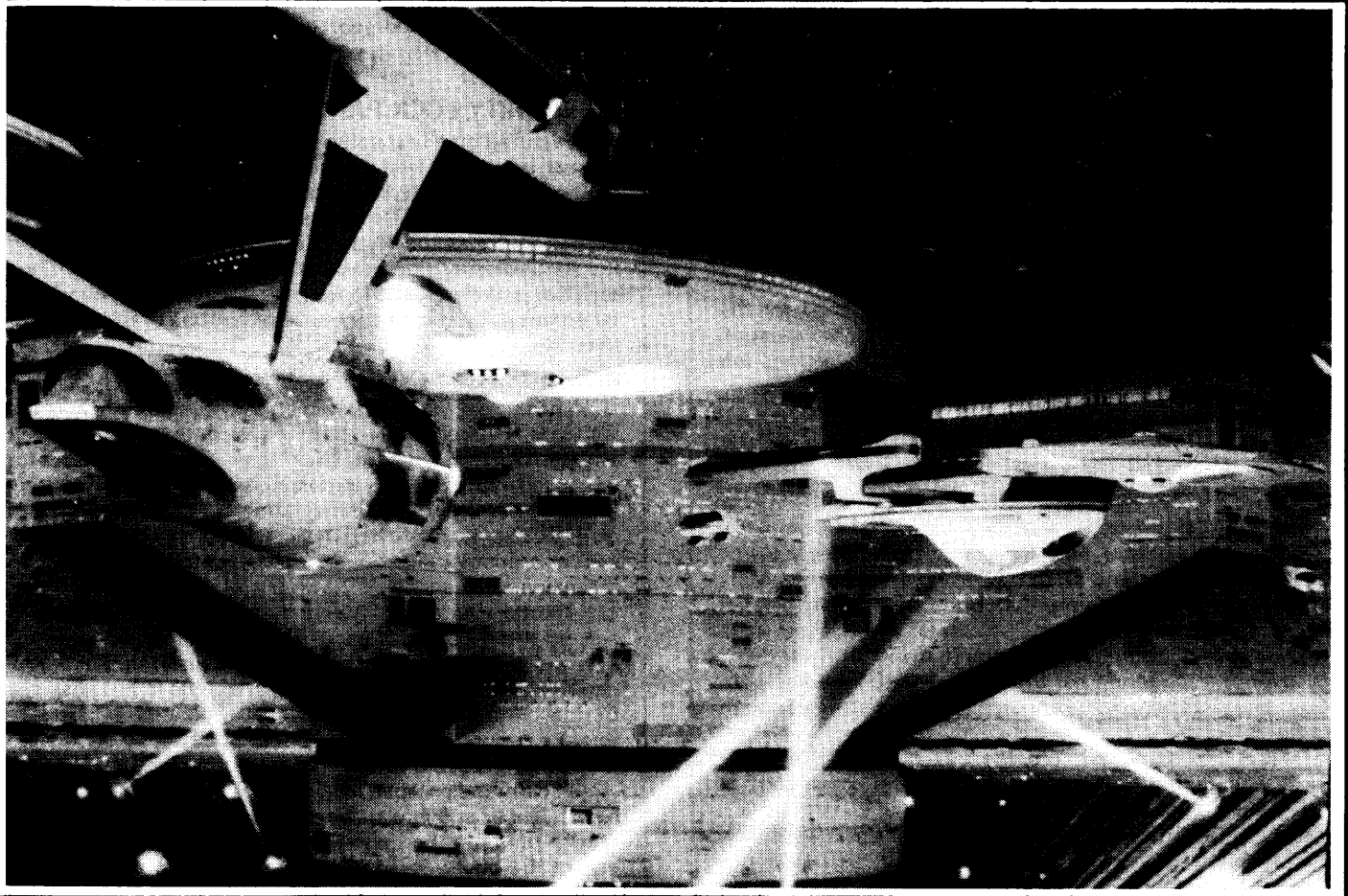

Data is included here for use with the **Starship Combat Game** and the **Ship Construction Manual**; these game statistics generally will not make sense without these publications.

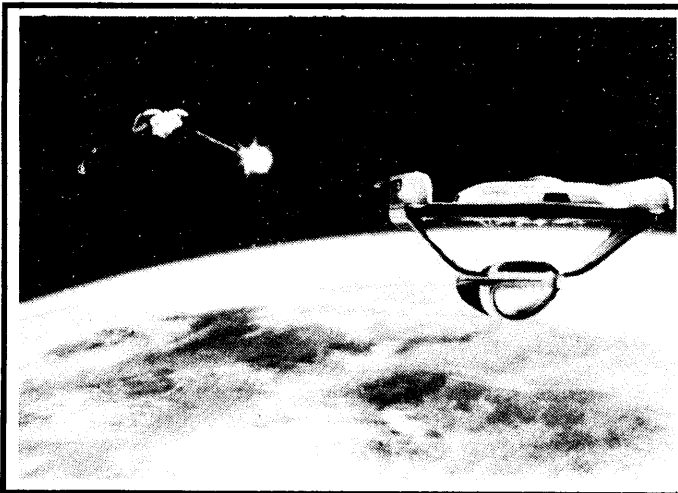

UNITED FEDERATION OF PLANETS

TECHNICAL DATA

Data For FTWA Trans-Warp Engine

Weight: 78,000 mt

Volume: 50,000 cu. meters

Power Units Available:

1 engine alone – 42

2 engines in tandem – 38 each

Movement Point Ratio:

1 engine alone – 7/1

2 engines in tandem – 6/1

Stress charts: D/F

Maximum Safe Cruising Speed:

1 engine alone – Warp 13

2 engines in tandem – Warp 12

Emergency Speed:

1 engine alone – Warp 15

2 engines in tandem – Warp 14

Ship size limits:

1 engine alone – 75,000 to 150,000 mt

2 engines in tandem – 150,000 to 300,000 mt

Data For FIG Impulse Engine

Weight: 1060 mt

Volume: 300 meters square and 3 decks tall

Power Units Available: 32

Ship Size Limits: 150,000 to 300,000 mt

SW-7 SHUTTLECRAFT AND WARPSLED

The SW-7 is the first standard Star Fleet shuttle capable of warp speed. It is now in use on many Star Fleet vessels, including the *Enterprise* class ships. The small, 7-passenger vehicle is not, by itself, warp capable. With the addition of the separate warpsled, however, the shuttle is capable of warp 2, making it theoretically capable of interstellar flight on its own.

The SW-7 is equipped with the standard Star Fleet docking collar and a side door. It can make atmospheric reentry and takeoff with or without the warpsled. Consumables aboard the shuttle make it suitable for trips of no more than 20 days length at maximum warp, though careful conservation might stretch that somewhat, and so any interstellar travel must be between two relatively close points.

The micro-warp engines of the shuttle are a Vulcan development, only useful on small vessels of under 7000 metric tons. The vessel is not armed for starship combat, nor does it have shielding beyond navigational deflectors.

Hull Data:

Numbers — None Assigned
Model Numbers — Mk I
Date Entering Service — 2/1408
Number Constructed — 2400
Sled Size
 Length — 50 m
 Width — 27 m
 Height — 9 m
 Weight — 1900 mt
Shuttle Size
 Length — 13 m
 Width — 11 m
 Height — 4 m
 Weight — 800 mt
 Cargo Units — 2

Engines And Power Data:

Total Power Units Available — 7
Movement Point Ratio — 2/1
Warp Engine Type — FMWA
 Number — 2
 Power Units Available — 2
 Stress Charts — A/A
 Maximum Safe Cruising Speed — Warp 2
 Emergency Speed — Warp 2
Impulse Engine Type — FIA
 Power Units Available — 3

Shields And Damage Control Data:

Superstructure Points — 1
Superstructure Damage Chart — A
Deflector Shield Type — Navigational Only

Other Data:

Crew — 2
Passengers — 6

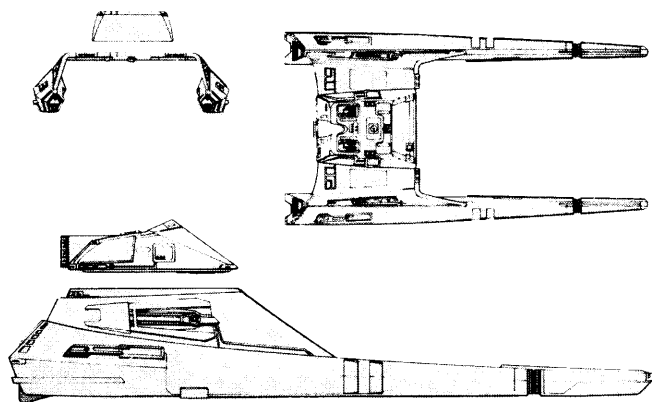
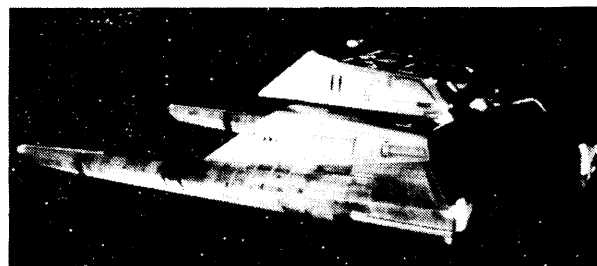
**S-10 TRAVEL POD**

The S-10 travel pod is a 6-passenger, light-duty shuttle normally used for point-to-point transfer of personnel between orbiting Star Fleet facilities. The travel pod has bench seating for 4 along the hull, in addition to the seats for the pilot and copilot. Controls for the travel pod can be operated comfortably either standing or sitting; given the travel pod's oversized front viewport and the short duration of the normal trip, many pilots prefer to stand while operating.

It is capable of atmospheric entry and takeoff under good conditions, but is not as rugged as the SW-7. It is equipped with the standard Star Fleet docking collar. Intended as VIP shuttles, captain's gigs, or other light duty, they are carried aboard larger vessels, including *Enterprise* class ships.

Hull Data:

Numbers — None Assigned
Model Numbers — Series 7
Date Entering Service — 2/1001
Number Constructed — 28,500
Size

Length — 4 m
 Width — 3 m
 Height — 3 m
 Weight — 4 mt
 Cargo Units — 2

Engines And Power Data:

Total Power Units Available — 1
Movement Point Ratio — 1/2
Impulse Engine Type — FMIA
 Number — 1
 Power Units Available — 1

Shields And Damage Control Data:

Superstructure Points — 0
Superstructure Damage Chart — C
Deflector Shield Type — Navigational Only

Other Data:

Crew — 1 or 2
Passengers — 4

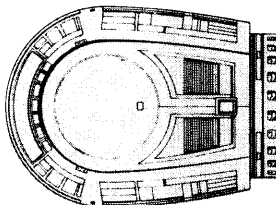
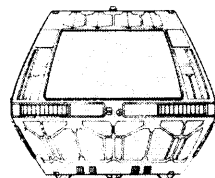
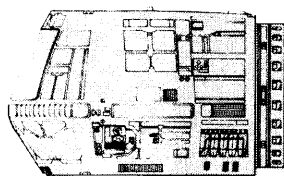
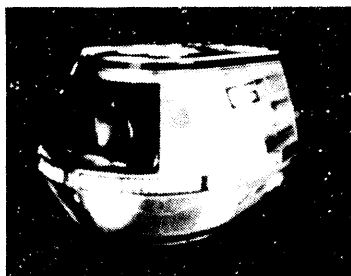

EXCELSIOR CLASS BATTLESHIP

This class presently contains but one experimental battleship: the largest, best-armed Star Fleet vessel ever built. After a trial period, others of its class eventually will be built. During its in-service trial, the vessel, called the *USS Excelsior*, bears the number NX-2000. (NX stands for 'Naval Experimental,' as opposed to the usual NCC code letters, which stand for 'Naval Construction Contract.')

The *Excelsior* class was designed to meet the mounting threats along the Klingon and Romulan borders; vessels of the class eventually will be stationed there, though the *USS Excelsior* is being kept deeper within the Federation, based at Terra during its trial.

The *USS Excelsior* is the first vessel equipped with the new Trans-warp engines. These engines deliver much more power and speed than any engine previously operational on such a large ship, and are controlled by an all-new, computerized, warp-envelope balancing system. The system grants a safety level far better than other warp engine systems, automatically adjusting warp power to transient demands smoothly and efficiently.

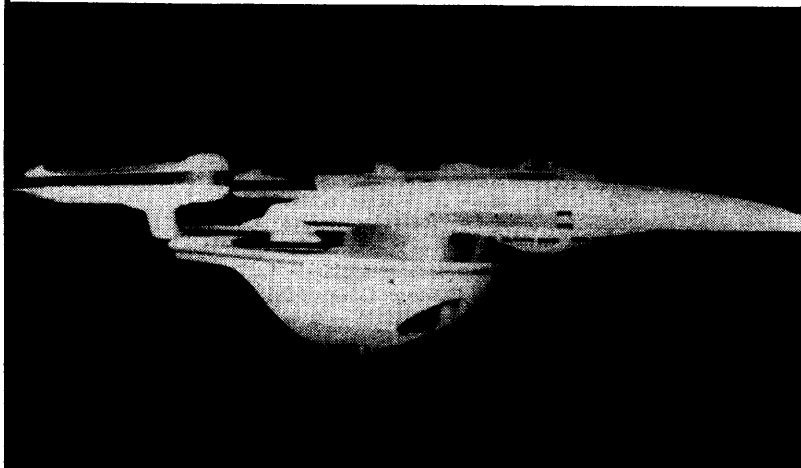
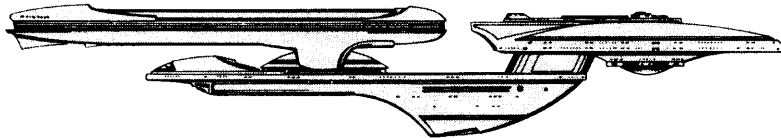
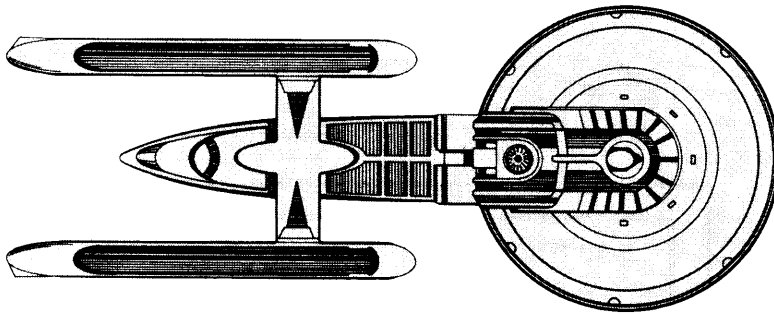

Hull Data:

Hull Number — NX-2000

Model Numbers — Experimental Model Only

Date Entering Service — Reference Stardate 2/2206

Number Constructed — 1

Size

Length — 467 m

Width — 186 m

Height — 78 m

Weight — 220,000 mt

Cargo Units — 550

Engines And Power Data:

Total Power Units Available — 108

Movement Point Ratio — 6/1

Warp Engine Type — FTWA

Number — 2

Power Units Available — 38

Stress Charts — D/F

Maximum Safe Cruising Speed — Warp 12

Emergency Speed — Warp 14

Impulse Engine Type — FIG

Power Units Available — 32

Weapons And Firing Data:

Beam Weapon Type — FH-11 Phaser

Number — 8, in 4 banks of 2

Firing Arcs — 2 fwd, 2 port, 2 stbd, 2 aft

Firing Chart — Y

Power Range — 0 - 10

Damage Modifiers —

+3(1 - 10) +2(11 - 17) +1(18 - 20)

Beam Weapon Type — FH-5 Phaser

Number — 8, in 4 banks of 2

Firing Arcs — 4 port, 4 stbd

Firing Chart — R

Power Range — 0 - 4

Damage Modifiers —

+2(1 - 8) +1(9 - 16)

Missile Weapon Type — FP-4 Photon Torpedo

Number — 4

Firing Arcs — 2 fwd, 2 aft

Firing Chart — S

Power To Arm — 1

Damage — 20

Shields And Damage Control Data:

Superstructure Points — 38

Superstructure Damage Chart — C

Deflector Shield Type — FSS

Shield Point Ratio — 1/4

Maximum Shield Power — 20

Other Data

Crew — 810

Shuttlecraft — 8 - 20

Transporters —

6 standard 6-person

6 emergency 22-person

3 cargo



Though this design was originally to be the new *Constitution* class, the first ship of the class built was called the *USS Enterprise* by popular demand, and thus the class was re-named. The superstructure of these ships is stronger than the old *Constitution* class ships, but new warp engine designs gives them a lighter overall weight. Photon torpedoes are mounted in a dorsal weapons pod, and docking facilities are built-in to receive the newer shuttles and travel pods.

The original designs called for 6 phaser weapons mounted in 3 banks of 2 — one bank forward under the main dish, one to port atop the dish, and one to starboard atop the dish. The *USS Enterprise* was sent out with this armament in the flight against *V'Ger*. In the final designs, there are 12 phaser weapons in 6 banks of 2; existing phaser mounts were paired with duplicates on the opposite side of the dish. Two banks are mounted forward (one atop the dish and one below), 2 banks are mounted port (one atop the dish and one below), and two banks are similarly mounted starboard. To avoid excessive drain on the power and fire control capabilities of the ship, each pair of banks, the one atop the dish and the one below, use the same power and fire control systems.

The effect is to fill what were considered gunnery blind spots, even though overall firepower is not significantly increased. Only one bank of a pair may be powered up and fired at any given time. Thus, either the top bank or the bottom bank, but not both, mounted forward may be powered and fired in any 10-second period.

The new *USS Enterprise* was fitted with the new 12-phaser mountings by Reference Stardate 2/2200. Most other *Enterprise* class ships still have the early 6-phaser mountings.

Technical Data: This doubling of the weapons is brought up at this time strictly for the sake of accuracy and for role-playing value. Only one from each pair of banks may be fired in one game turn. This arrangement affects starship combat very little. Because only one bank (containing 2 phaser weapons) of a matched pair can be powered at a time, simply treat the pair as one bank for powering or firing. For two-dimensional combat systems, including that from the **Starship Combat Game**, it makes no difference whether the phaser that fires is mounted at the top or on the bottom of the dish. Feel free to treat all *Enterprise* class vessels as having the original mountings only; it will not affect the play of the game.

If a phaser bank is knocked out during starship combat, the fire control equipment is affected and neither top nor bottom bank can fire. Gamemasters are warned not to allow players to find ways to get around the limitations of the system and fire more than one bank of a pair in a turn.

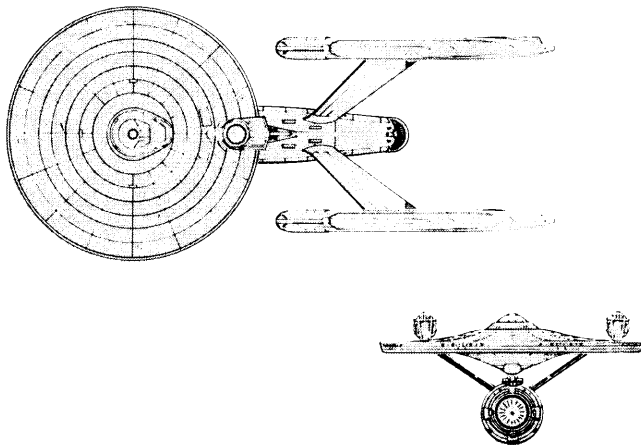

Hull Data:

Hull Numbers — 1701 — 1750
 Model Numbers — Mk I
 Date Entering Service — 2/1704
 Number Constructed — 17
 Size

Length — 302 m
 Width — 131 m
 Height — 74 m
 Weight — 170,000 mt
 Cargo Units — 450

Engines And Power Data:

Total Power Units Available — 60
 Movement Point Ratio — 4/1
 Warp Engine Type — FWG
 Number — 2
 Power Units Available — 26
 Stress Charts — D/F
 Maximum Safe Cruising Speed — Warp 8
 Emergency Speed — Warp 10
 Impulse Engine Type — FIE
 Power Units Available — 8

Weapons And Firing Data:

Beam Weapon Type — FH-11 Phaser
 Number — 12, in 3 pairs of banks,
 2 weapons per bank
 Firing Arcs — 2 fwd/port, 2 fwd, 2 fwd/stbd at any time
 Firing Chart — Y
 Power Range — 1 — 10
 Damage Modifiers — +3(1 — 10) +2(11 — 17) +1(18 — 24)
 Missile Weapon Type — FP-4 Photon Torpedo
 Number — 2
 Firing Arcs — fwd
 Firing Chart — S
 Power To Arm — 1
 Damage — 20

Shields And Damage Control Data:

Superstructure Points — 26
 Superstructure Damage Chart — C
 Deflector Shield Type — FSP
 Shield Point Ratio — 1/4
 Maximum Shield Power — 16

Other Data:

Crew — 412
 Shuttlecraft — 4 — 12
 Transporters —
 4 standard 6-person
 4 emergency 22-person
 2 cargo

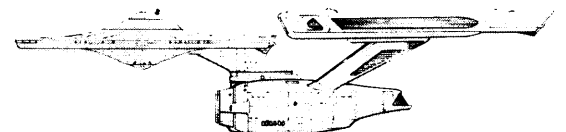
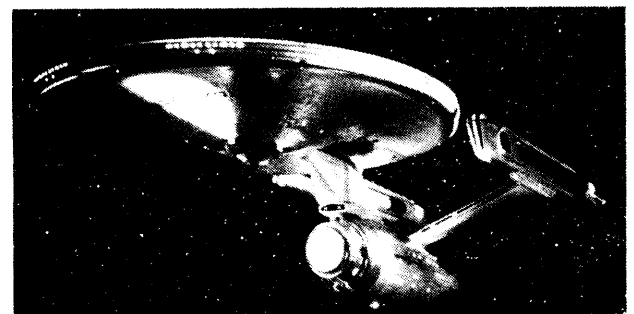

RELIANT CLASS RESEARCH CRUISER

The *Reliant* class is the refit version of the *Anton* class light cruiser. Though the original armament of the *Anton* class was hull mounted, the vessels proved too vulnerable, and so the refits mount a special weapons pod on a crossbar above the hull. This mounting method has proved more efficient for some designs, and gives the *Reliant* class a much better field of fire.

The original *USS Anton* was destroyed, and the first ship refitted was the *USS Reliant*, bringing about a change in the class name. The new design overran the hull number series set aside for the *Anton* class assigned for light cruiser duty. A new series was begun because the *Reliant* class proved to be quite useful as research support ships. The *USS Reliant* was since destroyed in the infamous "Wrath Of Khan" engagement against the *USS Enterprise*.

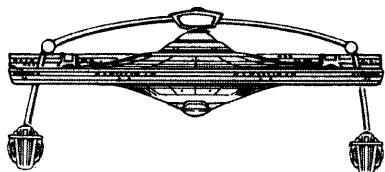
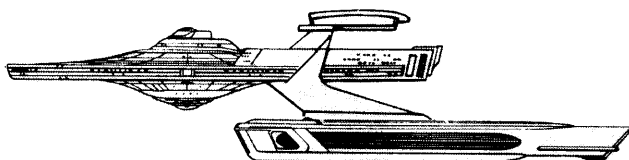
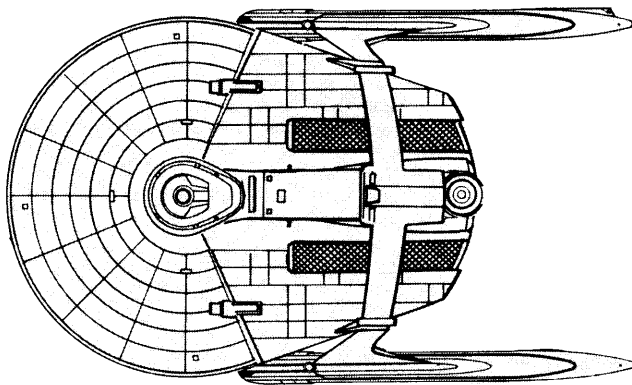

Hull Data:

Hull Numbers — 1860 — 1875
26226 — 26300
Model Numbers — Mk I
Date Entering Service — 2/1507
Number Constructed — 27
Size

Length — 233 m
Width — 140 m
Height — 64 m
Weight — 162,000 mt
Cargo Units — 400

Engines And Power Data:

Total Power Units Available — 48
Movement Point Ratio — 4/1
Warp Engine Type — FWF
Number — 2
Power Units Available — 20
Stress Charts — G/L
Maximum Safe Cruising Speed — Warp 6
Emergency Speed — Warp 8
Impulse Engine Type — FIE
Power Units Available — 8

Weapons And Firing Data:

Beam Weapon Type — FH-10 Phaser
Number — 4, in 2 banks of 2
Firing Arcs — 2 fwd/port, 2 fwd/stbd
Firing Chart — W
Power Range — 0 — 7
Damage Modifiers — +3(1 — 10) +2(11 — 17) +1(18 — 20)
Missile Weapon Type — FP-4 Photon Torpedo
Number — 2
Firing Arcs — 1 fwd, 1 aft
Firing Chart — S
Power To Arm — 1
Damage — 20

Shields And Damage Control Data:

Superstructure Points — 22
Superstructure Damage Chart — C
Deflector Shield Type — FSL
Shield Point Ratio — 1/3
Maximum Shield Power — 14

Other Data

Crew — 336, including up to 75 researchers
Shuttlecraft — 4
Transporters —
4 standard 6-person
3 emergency 22-person
2 cargo

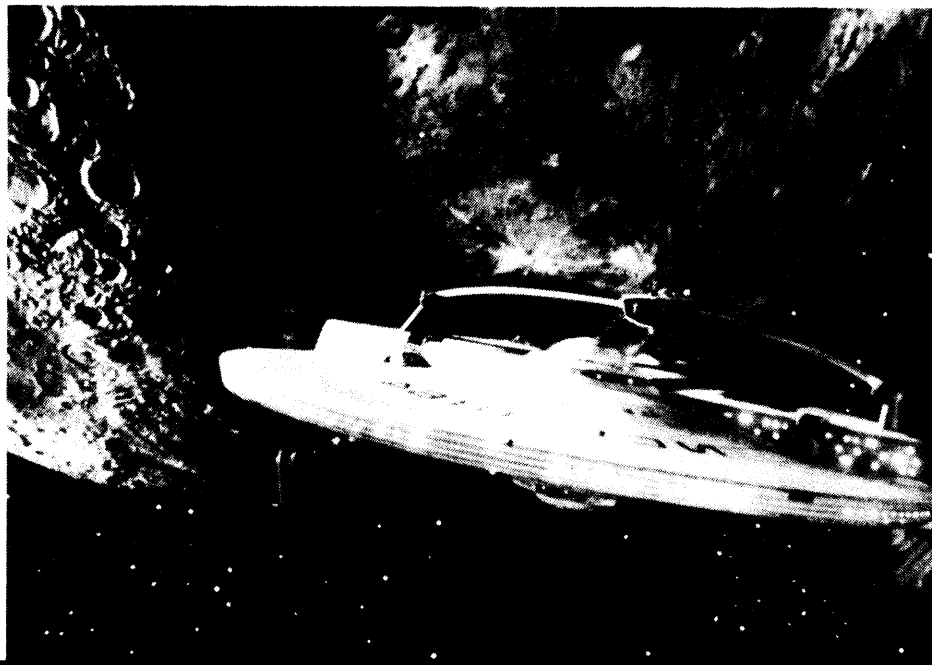

The *Gagarin* class ships were designed for low-risk, intensive surveys of new worlds. Advances in warp-drive shielding made it unnecessary for their low-yield warp nacelles to be mounted at an extended distance from the main hull. The engines remain detachable in case of emergency overload. Too undergunned to be used in frontier areas, the *Gagarin* class vessels only work deep in Federation-protected territory. Though they fulfilled their intended function, only 10 were constructed, as it was discovered that few surveys can truly be called 'low-risk.' The *USS Grissom* was utterly destroyed with ease by an attacking Klingon *Z'Gavva* Class Light Cruiser.

Hull Data:

Hull Numbers — 630 - 639
Model Numbers — Mk I
Date Entering Service — 2/1912
Number Constructed — 10
Size

Length — 148 m
 Width — 103 m
 Height — 59 m
 Weight — 41,000 mt
 Cargo Units — 95

Engines And Power Data:

Total Power Units Available — 22
Movement Point Ratio — 2/1
Warp Engine Type — FWB
 Number — 2
 Power Units Available — 9
 Stress Charts — M/O
 Maximum Safe Cruising Speed — Warp 7
 Emergency Speed — Warp 8
Impulse Engine Type — FIB
 Power Units Available — 4

Weapons And Firing Data:

Beam Weapon Type — FH-1 Phaser
 Number — 1
 Firing Arcs — fwd
 Firing Chart — F
 Power Range — 0-2
 Damage Modifiers — none

Shields And Damage Control Data:

Superstructure Points — 9
Superstructure Damage Chart — C
Deflector Shield Type — FSB
 Shield Point Ratio — 1/2
 Maximum Shield Power — 6

Other Data

Crew — 78
Shuttlecraft — 3
Transporters —
 2 standard 6-person
 1 emergency 22-person
 1 cargo

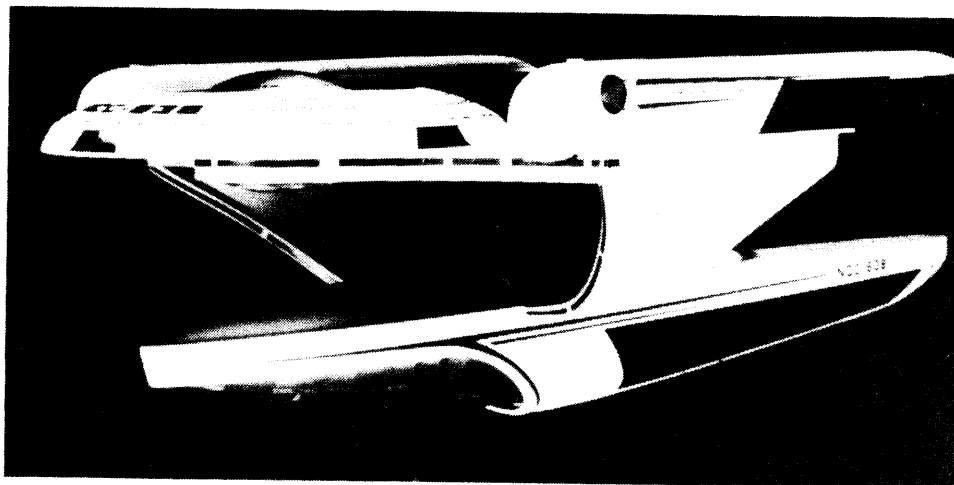
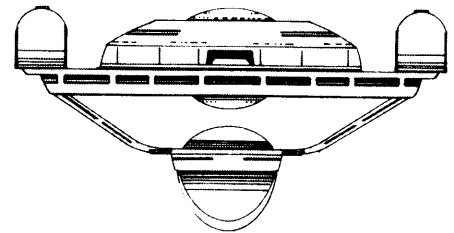
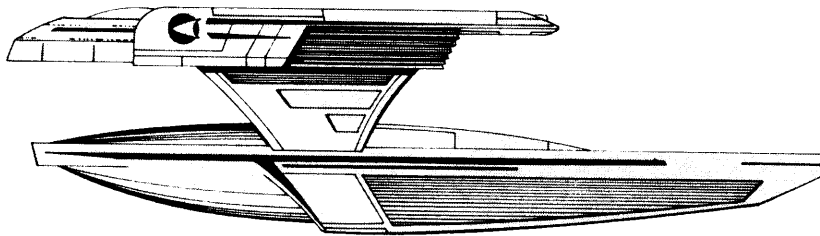
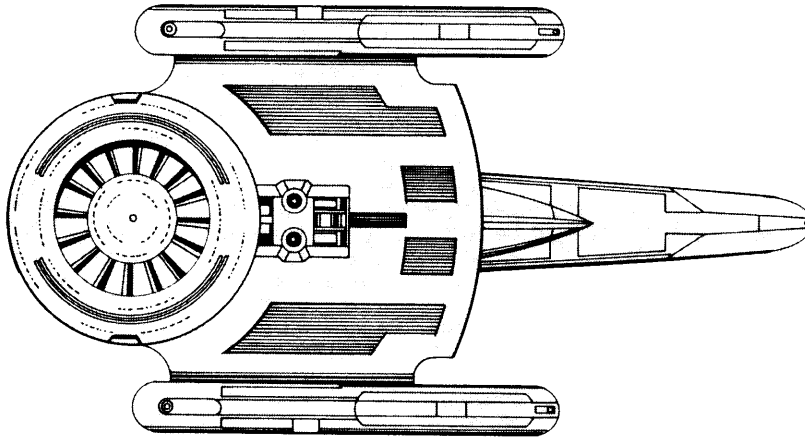

LOTUS FLOWER CLASS NEUTRONIC FUEL CARRIER

The *Lotus Flower* Class neutronic fuel carrier carries 97,000 tons of neutronic fuel. Because it is a civilian ship, it is unarmed but has defensive shields. The cruising and emergency speeds of the fully loaded ship are less than would be expected for their engine type because the concentrated weight of the neutronic fuel restricts performance.

The *Lotus Flower* Class vessels, Class III carriers, carry 300 passengers in addition to its fuel cargo. This is in contrast to Class I carriers, which are automated and carry neither passengers nor crew, and to Class II carriers, which carry crews but are not considered safe enough for passengers.

Neutronic fuel carriers are subsidized by Star Fleet because they are relied upon to transport neutronic fuel to outlying fleet installations. Neutronic fuel, used in most types of impulse engines as an expendable catalyst, is a prime target for piracy, and so these ships often travel with a Star Fleet escort.

The *Lotus Flower* class is most noted for one of its number that does not, in fact, exist. Star Fleet Academy's infamous *Kobayashi Maru* test scenario features a ship of this class as the victim of a gravitic mine attack. Though there is no real ship called the *Kobayashi Maru*, Star Fleet Registry traditionally lists this ship among the Federation's commercial carriers. The fictional vessel bears hull number H127499, is registered out of Amber Tau Ceti IV, and is commanded by merchant Captain Kojiro Yance.

Hull Data:

Hull Numbers — H127400 — H127499

Model Numbers — Mk 10

Date Entering Service — 2/0211

Number Constructed — 212

Size

Length — 237 m

Width — 73 m

Height — 49 m

Weight — 148,000 mt unloaded; 245 mt loaded

Cargo Units — 5000 SCU (97,000 mt) neutronic fuel

300 SCU other cargo

300 passengers

Engines And Power Data:

Total Power Units Available — 28

Movement Point Ratio — 6/1 unloaded; 7/1 loaded

Warp Engine Type — FWG

Number — 1

Power Units Available — 20

Stress Charts — C/D

Maximum Safe Cruising Speed — Warp 7 unloaded;

Warp 3 loaded

Emergency Speed — Warp 9 unloaded;

Warp 6 loaded

Impulse Engine Type — FID

Power Units Available — 8

Weapons And Firing Data: Unarmed

Shields And Damage Control Data:

Superstructure Points — 15

Superstructure Damage Chart — C

Deflector Shield Type — FSD

Shield Point Ratio — 1/2

Maximum Shield Power — 8

Other Data

Crew — 81

Shuttlecraft — 2

Transporters —

1 standard 6-person

3 emergency 22-person

1 cargo

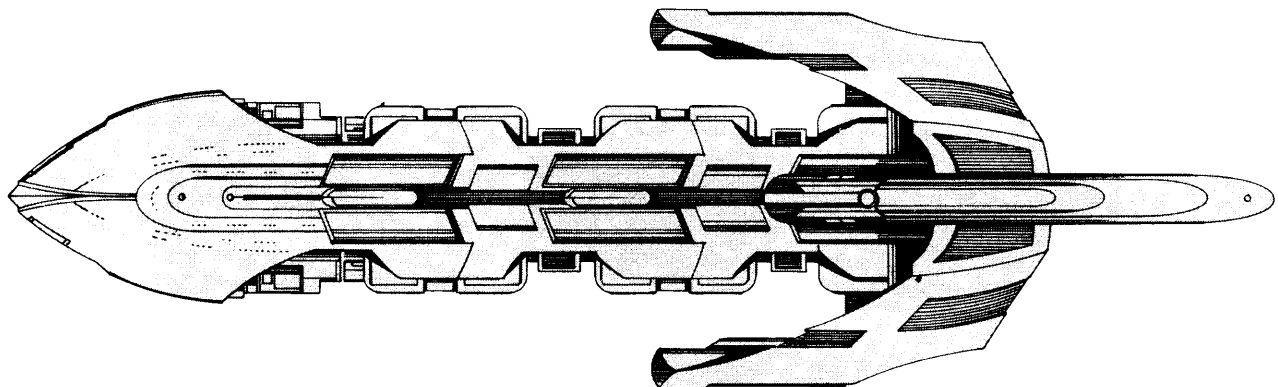
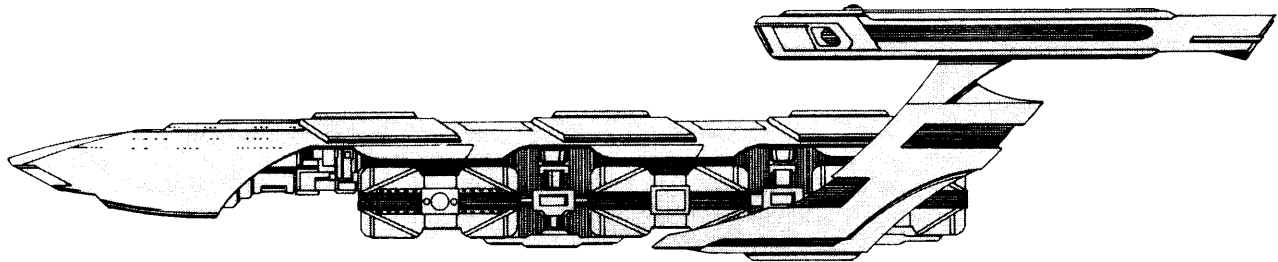
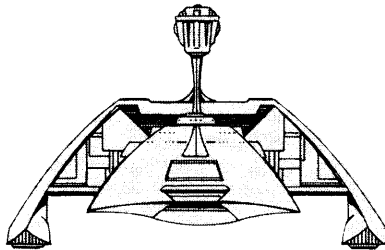

This gigantic, one-of-a-kind space station orbiting Terra is the most massive artificial satellite ever placed in orbit. Usually just referred to as the "Space Dock," the structure was completed and put into service on Reference Stardate 2/2011.05. It fills the need for more orbital docking facilities more elaborate than the free-standing, single-ship dock frameworks. The design includes orbital facilities for other uses, such as administrative offices, transient apartments, free-fall hospital facilities, and laboratories. The result was a kilometers-long station that dwarfs the mighty starships it services.

The Space Dock, despite its huge size, is an unarmed facility, built-in armament unnecessary considering its position in orbit around the most heavily-defended planet in the Federation. The station does possess special shield generators, more powerful than any others ever built. In addition, the huge matter/antimatter generators that power the station are quite capable of powering massive phaser batteries if, in time of war, Star Fleet should ever decide to mount them.

The Space Dock is home base for the new *USS Excelsior* battleship during its in-service testing period, as well as several other starships assigned to the quadrant containing the Sol/Terra system. It also is the home of special overhaul facilities used for starships too badly damaged for field repairs.

Hull Data:

Date Entering Service — 2/2011
Number Constructed — 1
Size
 Diameter — 3800 m
 Length — 4700 m
 Weight — 110,000,000 mt

Power Data:

Total Power Units Available — 550
Matter/Antimatter Power Generator Type — FMAPG-X1
 Number — 2
Power Units Available — 250
Impulse Power Generator Type — FIGP-X1
Power Units Available — 50

Weapons And Firing Data: Unarmed

Weapon Mounts Available
 Number — 40
Firing Arcs — 10 per quadrant

Shields And Damage Control Data:

Superstructure Points — 2000
Deflector Shield Type — FDSG-X1
Shield Point Ratio — 3/1
Maximum Shield Power — 35

Other Data:

Crew
Resident Operational Staff — 50000
Non-resident Staff — 4500
Resident Dependents — 100000
Transient Population — 20000 maximum
Shuttlecraft — 40-110
Transporters
 300 standard 6-person
 200 standard 2-person
 200 emergency 22-person
 100 standard cargo
 20 large-bulk cargo

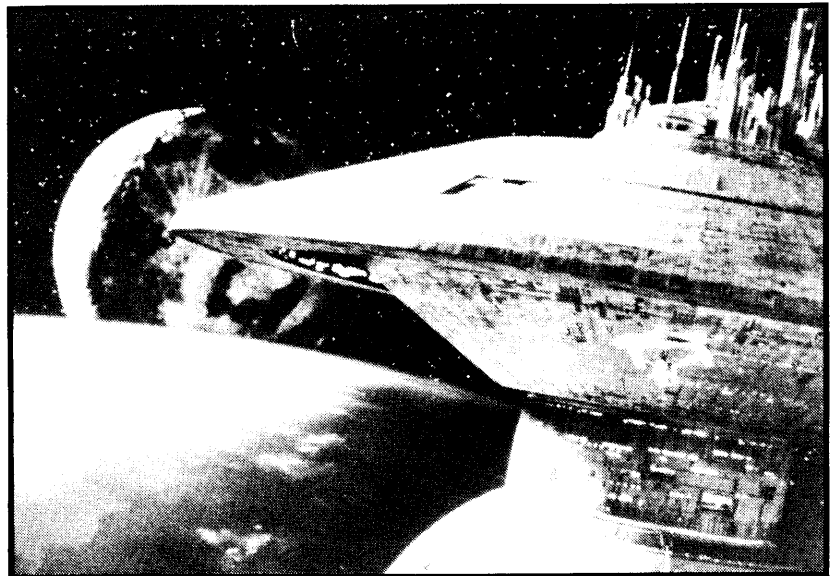
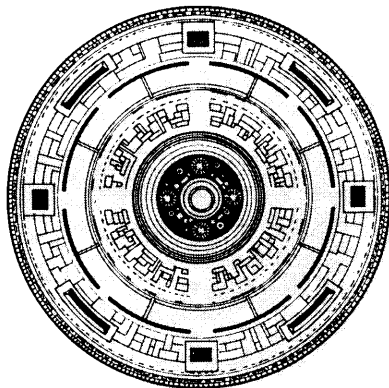
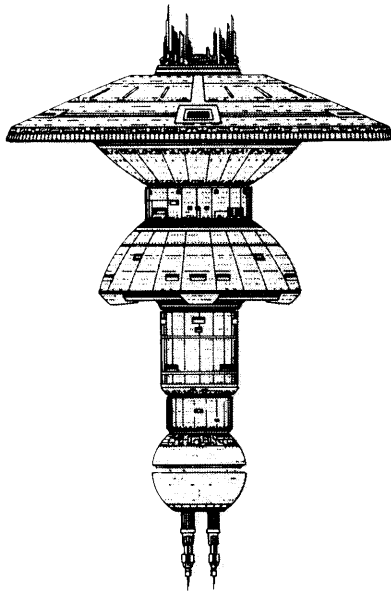

R1 TYPE ORBITAL STATION

The *R1* is a standard pre-fabricated orbital station that is widely used in the Federation. The basic design features a truncated cone as the main hull, including a large shuttle bay and several standard docking collars. At the small end of the cut-off cone is a smaller communications/sensor equipment area topped with a communications mast. Though most stations are unarmed, 8 hardpoints are available for weapons mounts, if desired. Some stations have only navigational deflectors, while others are equipped with combat-quality shields.

Attached to the broad end of the cone are several smaller, deck section modules, including an engineering deck. One of these decks can be a horizontal bar-shaped extension to which four circular pod modules may be attached for special functions.

Below the modular special decks are four cylindrical pods parallel to the long axis of the station; most often these contain such consumables as water, air, and food base. The large capacity of these storage tanks gives the stations a longer operational life between supply shipments. Thus, stations of this type are ideal for use in frontier areas, or out-of-the-way areas infrequently visited by cargo ships.

Power is provided by a matter/antimatter generator and an auxiliary impulse power generator. Though these are not engines and cannot move the station, their power output is equivalent to a standard warp or impulse engine type. The matter/antimatter generator is usually contained in one of the cylindrical pods so it can be jettisoned if necessary.

These stations are constructed in orbit from several Star Fleet major construction facilities. After construction, they may be towed intact by a specially-designed warp-tender that attaches to built-in, reinforced, grappling points on the hull. A station that has outlived its usefulness in one location can be moved to another spot, or it may be returned for refitting. Once in place, the station cannot be moved without the warp-tender, except for orbital corrections accomplished with small ion thrusters.

Variants of this basic design are used as manufacturing facilities, research stations, observation posts, orbital administrative offices, and so on. Two well-known examples of the design are the ill-fated *Regula I* Deep Space Research Station, originally under the authority of Dr. Carol Marcus, and the Orbital Administration Facility of Star Fleet's San Francisco Naval Yards, Terra. Statistics are given for both the unarmed research variant (like the *Regula I*), and for an armed border post.

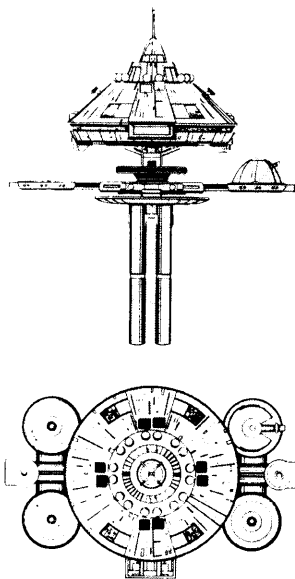

R-1 TYPE ORBITAL BORDER OUTPOST

Hull Data:

Date Entering Service — 2/0911

Number Constructed — 63

Size

Diameter — 200 m

Length — 215 m

Weight — 1,103,000 mt

Power Data:

Total Power Units Available — 24

Matter/Antimatter Power Generator Type — FMAPG-FWF

Number — 1

Power Units Available — 20

Impulse Power Generator Type — FIPG-FID

Power Units Available — 4

Weapons And Firing Data:

Beam Weapon Type — FH-6 Phaser

Number — 8, in 4 banks of 2

Firing Arcs — 2 banks per quadrant

Firing Chart — N

Power Range — 0-3

Damage Modifiers —

+ 2(1-7) + 1(8-13)

Missile Weapon Type — FP-2 Photon Torpedo

Number — 4

Firing Arcs — 2 per quadrant

Firing Chart — H

Power To Arm — 1

Damage — 6

Shields And Damage Control Data:

Superstructure Points — 24

Deflector Shield Type — FSF

Shield Point Ratio — 1/2

Maximum Shield Power — 10

Other Data

Crew — 185

Shuttlecraft — 0-4

Transporters —

1 standard 6-person

2 cargo

R-1 TYPE ORBITAL RESEARCH STATION

Hull Data:

Date Entering Service — 2/0902

Number Constructed — 22

Size

Diameter — 200 m

Length — 215 m

Weight — 854,000 mt

Power Data:

Total Power Units Available — 24

Matter/Antimatter Power Generator Type — FMAPG-FWF

Number — 1

Power Units Available — 20

Impulse Power Generator Type — FIPG-FID

Power Units Available — 4

Weapons And Firing Data: None

Shields And Damage Control Data:

Superstructure Points — 24

Deflector Shield Type — Navigational Only

Other Data

Crew — 150

Shuttlecraft — 0-8

Transporters

1 standard 6-person

2 cargo

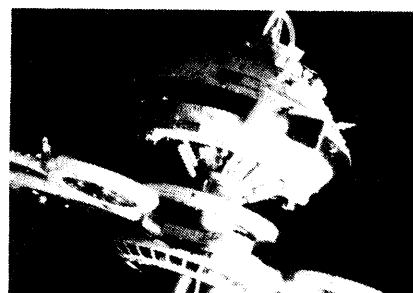

The *Samson* class warp-tender was designed by Onto Rantura and built by Chiokis Shipyards especially to tow the *R-1* Orbital Station. It is basically a pair of big warp engines with a hull to hold them together and house crew, tractor beam equipment, towing hookups, and so on. Even with two big warp engines, these ships are well over tonnage rating when towing a station, and thus move more slowly when laden than is normal for their engines. These vessels have only minimum defensive shields and no offensive armament to drain power. For this reason, they never travel unescorted.

Three heavy-duty, extensible, towing arms attach to the station, but they do not bear all of the towing burden. Several heavy-duty tractor/pressor beams also are installed for towing. These beams are so powerful that they actually draw an appreciable amount of ship's power when active, as is noted in the specifications.

Hull Data:

Hull Numbers — 92300 — 92310
 Model Number — Mk I
 Date Entering Service — 2/0902
 Number Constructed — 26
 Size

Length — 200 m
 Width — 140 m
 Height — 60 m
 Weight — 152,000 mt
 Cargo Units — 0

Engines And Power Data:

Total Power Units Available — 44
 Movement Point Ratio — 4/1 unloaded
 8/1 loaded

Warp Engine Type — FWF
 Number — 2
 Power Units Available — 20
 Stress Charts — G/L
 Maximum Safe Cruising Speed — Warp 6 unloaded
 Warp 3 loaded
 Emergency Speed — Warp 8 unloaded
 Warp 5 loaded

Impulse Engine Type — FID
 Power Units Available — 4

Weapons And Firing Data: Unarmed

Shields And Damage Control Data:

Superstructure Points — 20
 Superstructure Damage Chart — B
 Consider 'Beam Weapon Hits' As 'Tractor Beam' Hits
 Deflector Shield Type — FSB
 Shield Point Ratio — 1/2
 Maximum Shield Power — 6

Other Data

Crew — 52
 Shuttlecraft — 2
 Transporters — 1 standard 6-person
 Tractor Beam Type — FTB-6
 Number — 3
 Power Drain — 3
 Number Needed For *R-1* Orbital Station
 Sub-light-speed Maneuvers — 1
 Warp Speed Maneuvers — 2

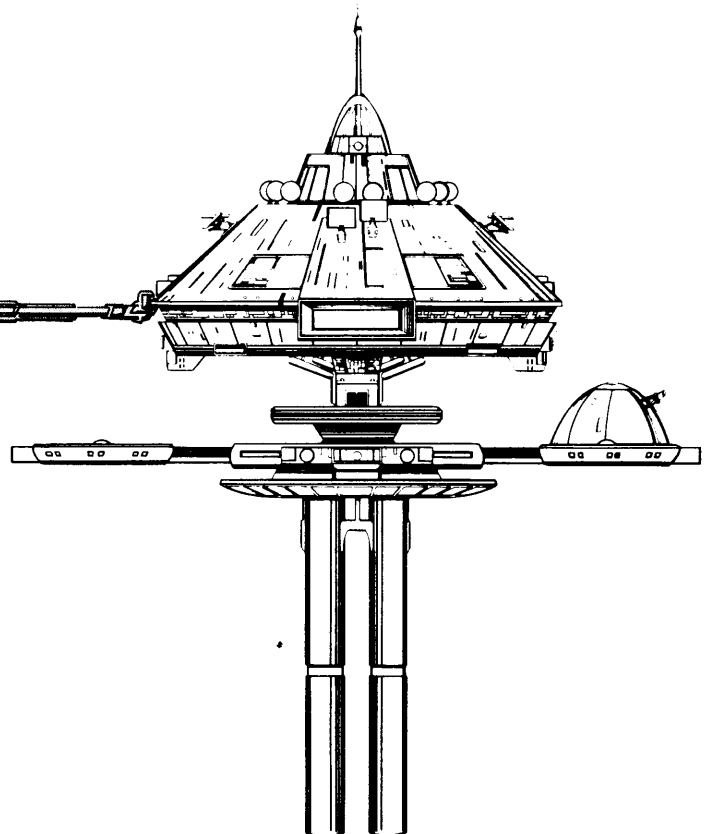
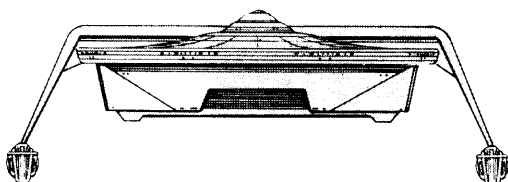
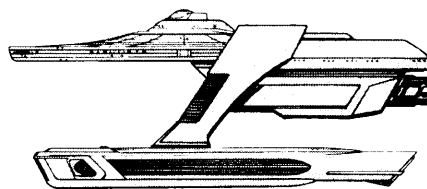
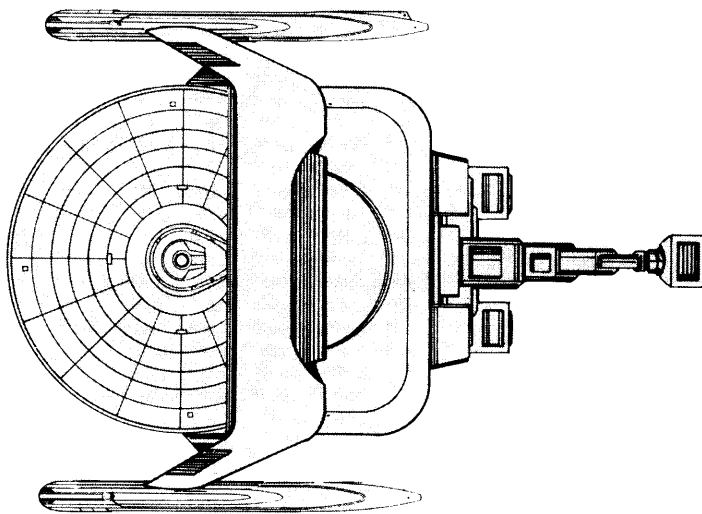

D-7M (K'T'INGA) CLASS LIGHT CRUISER

The M variant of the D-7 class light cruiser, called the *K't'inga* class by the Klingons, is a much-improved version of the original A type. It retains the virtues of the D-7A, but has improved firepower and movement. The addition of torpedo weapons mounted singly forward and aft make it a nasty opponent, especially when deployed in groups of three.

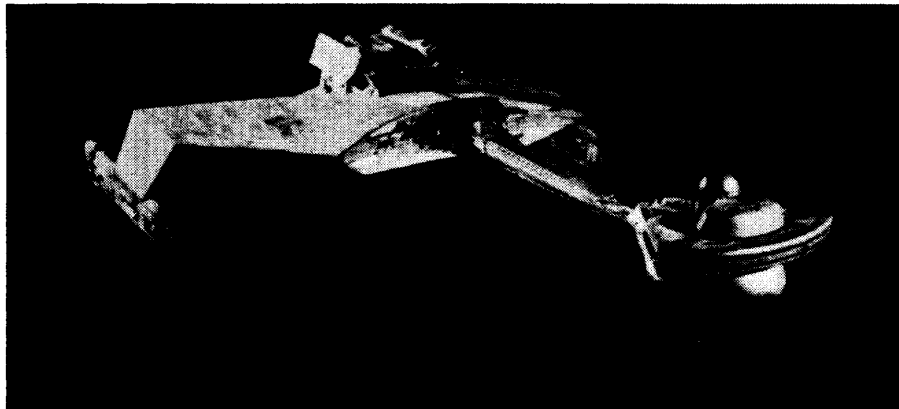
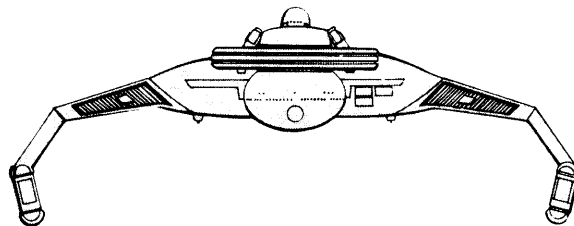
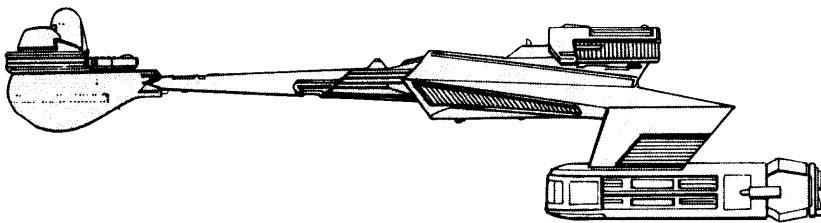
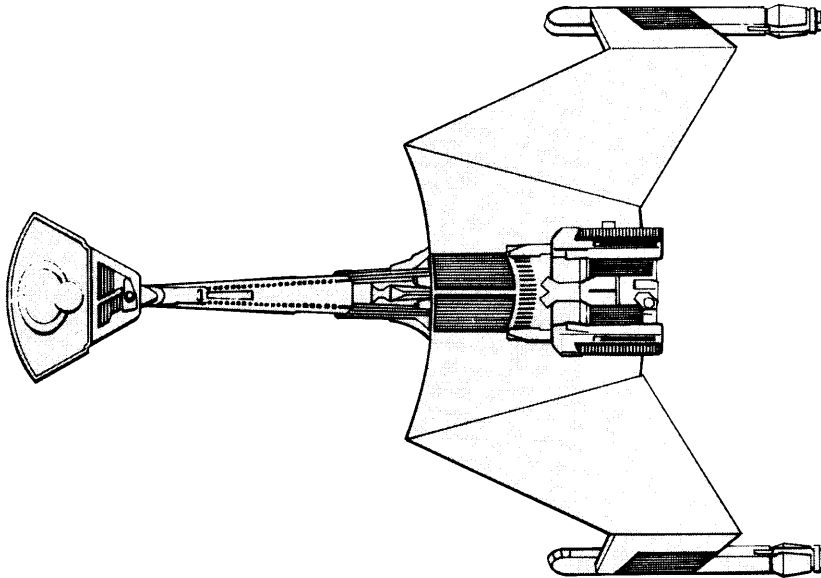

Hull Data:

Class — K't'inga
Model Numbers — M
Date Entering Service — 2/1105
Number Constructed — 88
Size

Length — 221 m
Width — 156 m
Height — 62 m
Weight — 118,000 mt
Cargo Units — 120

Engines And Power Data:

Total Power Units Available — 44
Movement Point Ratio — 3/1
Warp Engine Type — KWE
Number — 2
Power Units Available — 20
Stress Charts — J/M
Maximum Safe Cruising Speed — Warp 8
Emergency Speed — Warp 9
Impulse Engine Type — KIC
Power Units Available — 4

Weapons And Firing Data:

Beam Weapon Type — KD-8 Disruptor
Number — 4
Firing Arcs — 2 fwd/port, 2 fwd/stbd
Firing Chart — U
Power Range — 0-7
Damage Modifiers —
+ 3(1-10) + 2(11-17) + 1(18-24)

Missile Weapon Type — KP-3 Torpedo

Number — 2
Firing Arcs — 1 fwd, 1 aft
Firing Chart — R
Power To Arm — 2
Damage — 15

Shields And Damage Control Data:

Superstructure Points — 20
Superstructure Damage Chart — C
Deflector Shield Type — KSK
Shield Point Ratio — 1/2
Maximum Shield Power — 12

Other Data

Crew — 373
Shuttlecraft — 5
Transporters
3 standard 6-person
1 emergency 18-person
5 combat-drop 22-person
2 cargo

This starship is one example of a true blending of Klingon and Romulan technology resulting from their technological exchange treaties. The design is Romulan, as shown by the sleek lines of a carnivorous bird, and the power plants and weapons are Klingon.

The ship is designed to land on a planet if necessary. The wings have three positions: swept up for landings, straight out for normal flight, and swept down for attacks. The warp drives are built into the hull rather than being on struts or pylons. This renders them less vulnerable, but affords the ship no chance to jettison them in case of overload. To the Klingons, this is an acceptable risk.

The cloaking device is of the latest Romulan design. To protect the secret, the device is installed on the Klingon ships by Romulan technicians. The Klingons can operate it and even repair it to some extent, but they cannot disassemble it or duplicate it.

The Klingons liked the design so much that they have enlarged and strengthened it, making the *D-32 Class Light Cruiser* and the *L-42 Class Frigate*.

Hull Data:

Class — D'Gavama; Bird Of Prey
Model Numbers — A
Date Entering Service — 2/1909
Number Constructed — 60

Size

Length — 88 m
 Width — 130 m
 Height — 16 m
 Weight — 38,000 mt
 Cargo Units — 5

Engines And Power Data:

Total Power Units Available — 25
Movement Point Ratio — 2/1
Warp Engine Type — KWC
 Number — 1
 Power Units Available — 22
Stress Charts — L/M
Maximum Safe Cruising Speed — Warp 7
Emergency Speed — Warp 8
Impulse Engine Type — KIB
 Power Units Available — 3

Weapons And Firing Data:

Beam Weapon Type — KD-8 Disruptor
 Number — 2
Firing Arcs — fwd/port, fwd/stbd, fwd/port/stbd
Firing Chart — U
Power Range — 0-7
Damage Modifiers —
 +3(1-7) +2(8-15) +1(16-20)
Missile Weapon Type — KP-5 Photon Torpedo
 Number — 1
Firing Arcs — 1 fwd
Firing Chart — Q
Power To Arm — 1
 Damage — 10

Shields And Damage Control Data:

Superstructure Points — 10
Superstructure Damage Chart — C
Deflector Shield Type — KSC
Shield Point Ratio — 1/1
 Maximum Shield Power — 8

Other Data:

Crew — 12
Shuttlecraft — 0; ship is landing capable
Transporters
 1 standard 6-person
Cloaking Device Type — KCB
 Number — 1
 Power Requirement — 22 power units

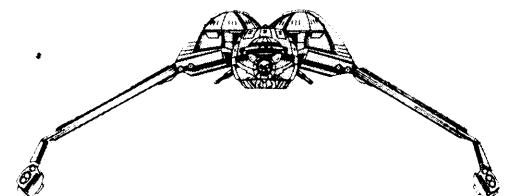
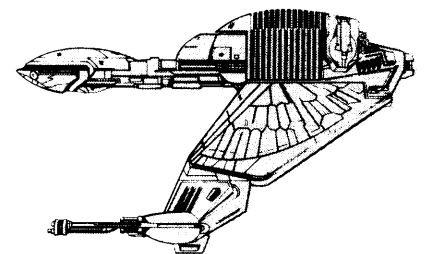
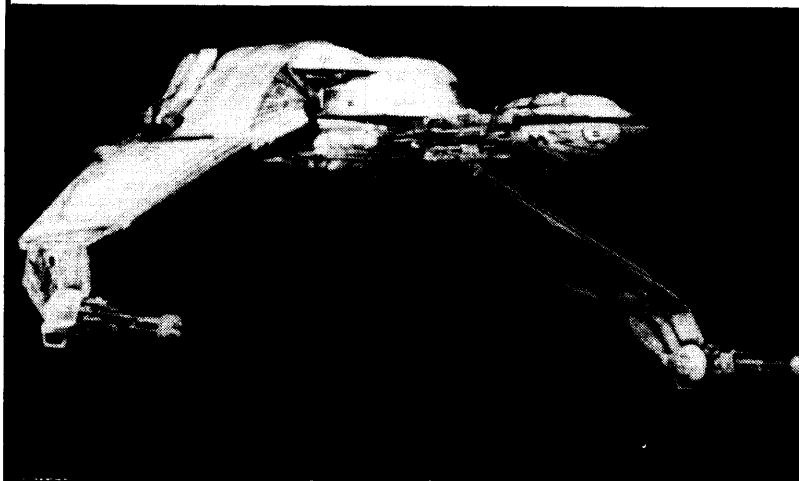
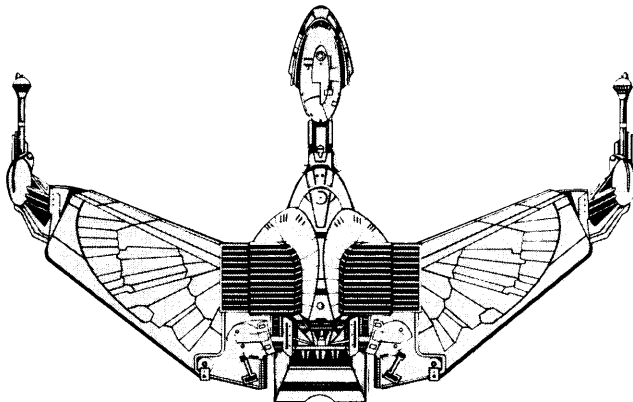

STAR FLEET PERSONNEL FILE

The crew of the *USS Enterprise* are the most capable in Star Fleet. Skill Ratings and Attribute Scores for *STAR TREK's* familiar characters have been created based on observations of the TV series, traditional fan thoughts and additions, and random speculation. They are above average, for the most part, and most player characters are not likely to have their depth and breadth. These characters are provided here so that players can have models for their own characters. They could even be used by players, particularly by those not already experienced with role-playing games, or they may be recurring NPCs at the gamemaster's option.



Name: KIRK, James Tiberius
Rank: Admiral
Serial No.: SC937 - 0176CEC
Current Assignment: Star Fleet Education and Training Command
Position: Chief of Field Training Bureau, Star Fleet Academy
Race: Human
Birthplace: Terra/United States of America
Age: 49
Sex: Male
 STR - 68 CHA - 94
 END - 77 LUC - 98
 INT - 84 PSI - 29
 DEX - 79
 To-Hit Modern: 80 Bare-Hand Damage: 1D10 + 8
 HTH: 81 AP - 11

Significant Skills:

Skill	Rating
Administration	69
Carousing	62
Communication Systems Operation	45
Communication Systems Technology	13
Computer Operation	56
Computer Technology	10
Damage Control Procedures	37
Deflector Shield Operation	21
Electronics Technology	10
Environmental Suit Operation	59
Gaming	89
Instruction	63
Language, Orion	23
Leadership	92
Marksmanship, Archaic Firearms	36
Marksmanship, Modern Weapon	81

Medical Sciences	Rating
General Medicine, Human	12
Psychology, Human	49
Negotiation/Diplomacy	97
Small Equipment Systems Operation	14
Small Equipment Systems Technology	11
Small Unit Tactics	64
Social Sciences	
Federation History	64
Federation Law	86
Space Sciences	
Astrogration	79
Astronautics	22
Astronomy	53
Astrophysics	48
Starship Combat Strategy/Tactics	96
Starship Helm Operation	62
Personal Combat, Unarmed	83
Personal Weapons Technology	21

Physical Sciences	Rating
Mathematics	28
Physics	15
Planetary Survival, Cool Temperate	66
Security Procedures	52
Shuttlecraft Pilot	49
Shuttlecraft Systems Technology	11
Starship Sensors	41
Starship Weaponry Operation	32
Starship Weaponry Technology	29
Streetwise	79
Transporter Operation Procedures	66
Trivia	
Life of Abe Lincoln	91
American History	84
Vehicle Operation, Ground	06
Warp Drive Technology	33
Zero-G Operations	45

Commendations: Palm Leaf of Axanar Peace Mission; Gran-kite Order of Tactics, Class of Excellence; Prantares Ribbon of Commendation, First and Second Class.

Awards Of Valor: Medal of Honor; Silver Palm with Cluster; Star Fleet Citation for Conspicuous Gallantry; Karagite Order of Heroism

Notes: Once contracted Vegan choriomeningitis, and still carries microorganisms in his bloodstream.

Name: SPOCK
Rank: Captain
Serial No.: S179 - 276SP
Current Assignment: Galaxy Exploration Command, *USS Enterprise*, NCC - 1701
Position: Commanding Officer
Race: mixed Vulcan/Human
Birthplace: Vulcan/ShiKahr
Age: 55 +
Sex: Male
 STR - 93 CHA - 62
 END - 82 LUC - 41
 INT - 102 PSI - 97
 DEX - 73
 To-Hit Modern: 57 Bare-Hand Damage: 2D10 + 6
 HTH: 68 AP - 11

Significant Skills:

Skill	Rating
Administration	56
Artistic Expression, Vulcan Lyre	86
Communication Systems Operation	14
Communication Systems Technology	44
Computer Operation	93
Computer Technology	58
Damage Control Procedures	48
Deflector Shield Operation	12
Electronics Technology	26
Environmental Suit Operation	30
Gaming	91
Instruction	53
Language	
English	48
Vulcan	60
Leadership	56
Life Sciences	
Bionics	13
Botany	44
Ecology	45
Exobiology	40
Genetics	23
Zoology	51
Life Support System Technology	18

Marksmanship, Modern Weapon	Rating
Mechanical Engineering	26
Medical Sciences	
General Medicine, Vulcan	15
Human	15
Pathology	13
Psychology, Human	14
Negotiation/Diplomacy	71
Personal Combat, Unarmed	64
Personal Weapons Technology	36
Physical Sciences	
Chemistry	31
Computer Science	92
Mathematics	80
Physics	77
Planetary Sciences	
Geology	44
Hydrology	22
Meteorology	12
Planetary Survival, Desert	51
Security Procedures	17
Shuttlecraft Pilot	47
Shuttlecraft Systems Technology	23
Small Equipment Systems Operation	20
Small Equipment Systems Technology	31

Social Sciences	Rating
Archaeology, Terran	56
Federation History	56
Federation Law	65
Political Science	44
Racial Culture/History, Human	62
Space Sciences	
Astrogration	46
Astronautics	51
Astronomy	69
Astrophysics	68
Starship Combat Strategy/Tactics	58
Starship Helm Operation	35
Starship Sensors	92
Starship Weaponry Operation	14
Starship Weaponry Technology	39
Streetwise	15
Transporter Operation Procedures	71
Transporter Systems Technology	42
Trivia	
Terran Artists	37
Terran Poetry	42
Terran Religious Literature	27
Warp Drive Technology	39
Zero-G Operations	38

Commendations: Vulcan Scientific Legion of Honor; twice decorated by Star Fleet Command

Awards Of Valor: Star Fleet Award of Valor

Notes: Rare blood type - T-negative

Name: SULU, Hikaru W.
Rank: Commander
Serial No.: SH7730 - 4967
Current Assignment: Galaxy Exploration Command,
USS Enterprise, NCC - 1701
Position: Chief Helmsman
Race: Human **Age:** 46
Birthplace: Terra **Sex:** Male

STR - 65 CHA - 79
 END - 63 LUC - 81
 INT - 82 PSI - 21
 DEX - 88

To-Hit Modern: 76 Bare-Hand Damage: 1D10 + 9
 HTH: 70 AP - 12
 Sword: 72 Pistol: 72

Significant Skills:

Skill	Rating
Administration	40
Carousing	41
Communication Systems Operation	31
Computer Operation	44
Computer Technology	29
Damage Control Procedures	47
Deflector Shield Operation	32
Director Shield Technology	28
Electronics Technology	45
Environmental Suit Operation	31
Instruction	31
Language, Tellarite	15
Leadership	48
Life Sciences	
Botany	77

Exobiology	38	Social Sciences	
Marksmanship, Archaic Pistols	55	Federation History	30
Marksmanship, Modern Weapon	65	Federation Law	32
Medical Sciences, Gen. Med., Human	12	Space Sciences	
Negotiation/Diplomacy	27	Astrogration	79
Personal Combat, Sword	56	Astronautics	23
Personal Combat, Unarmed	52	Astronomy	65
Personal Weapons Technology	5	Astrophysics	62
Physical Sciences		Starship Combat Strategy/Tactics	69
Mathematics	15	Starship Helm Operation	90
Physics	21	Starship Sensors	59
Planetary Sciences, Geology	13	Starship Weaponry Operation	48
Planetary Survival, Warm Temperate	28	Starship Weaponry Technology	42
Security Procedures	49	Streetwise	51
Shuttlecraft Pilot	66	Transporter Operation Procedures	35
Small Equipment Systems Operation	14	Trivia, Ancient Firearms	89
Small Unit Tactics	19	Warp Drive Technology	16
		Zero-G Operations	21



Name: McCoy, Leonard, M.D.
Rank: Commander
Serial No.: SM831 - 3840
Current Assignment: Galaxy Exploration Command,
USS Enterprise, NCC - 1701
Position: Chief Medical Officer
Race: Human **Age:** 60
Birthplace: Terra/United States Of America **Sex:** Male

STR - 52 CHA - 81
 END - 53 LUC - 66
 INT - 83 PSI - 52
 DEX - 76

To-Hit Modern: 53 Bare-Hand Damage: 1D10 + 6
 HTH: 53 AP - 11

Significant Skills:

Skill	Rating
Administration	43
Carousing	44
Computer Operation	45
Damage Control Procedures	12
Electronics Technology	17
Environmental Suit Operation	24
Instruction	49
Language, Latin	47
Leadership	47
Life Sciences	
Bionics	60
Botany	53
Ecology	52
Exobiology	36

Genetics	52	Mathematics	12
Zoology	38	Physics	20
Life Support Systems Technology	34	Planetary Sciences, Meteorology	17
Marksmanship, Modern Weapon	30	Planetary Survival, Cool Temperate	26
Medical Sciences		Small Equipment Systems Operation	23
General Medicine, Human	97	Social Sciences	
Vulcan	49	Federation History	38
Pathology	67	Federation Law	44
Psychology, Human	57	Space Sciences	
Vulcan	32	Astrogration	10
Andorian	20	Astronomy	13
Surgery	92	Astrophysics	16
Negotiation/Diplomacy	66	Starship Sensors	34
Personal Combat, Unarmed	32	Streetwise	52
Physical Sciences		Transporter Operation Procedures	15
Chemistry	46	Zero-G Operations	14

Commendations: Legion Of Honor

Awards Of Valor: Decorated by Star Fleet Surgeons; Star Fleet Award Of Valor

Notes: Divorced with one child, Joanna, 35

Name: UHURA
Rank: Commander
Serial No.: SK2561 - 1122
Current Assignment: Galaxy Exploration Command,
USS Enterprise, NCC - 1701
Position: Chief Communications Officer
Race: Human **Age:** 44
Birthplace: Terra/United States of Africa **Sex:** Female

STR - 54 CHA - 86
 END - 62 LUC - 71
 INT - 83 PSI - 52
 DEX - 76

To-Hit Modern: 53 Bare-Hand Damage: 1D10 + 6
 HTH: 53 AP - 11

Significant Skills:

Skill	Rating
Administration	42
Artistic Expression, Harp	62
Vulcan Lyre	31
Vocal Music	94
Carousing	36
Communication Systems Operation	92
Communication Systems Technology	93
Computer Operation	65
Computer Technology	36
Damage Control Procedures	89
Electronics Technology	38
Environmental Suit Operation	18
Gaming	39
Instruction	38
Language	
Swahili	49
French	48
Galacta	64
Gorn	19

Klingonaase	46	Social Sciences	
Orion	28	Federation History	39
Romulan	30	Federation Law	44
Leadership	52	Racial Culture/History, Andorian	12
Life Sciences, Exobiology	14	Vulcan	23
Marksmanship, Modern Weapon	32	Ancient African	86
Mechanical Engineering	24	Klingonaase	18
Medical Sciences		Space Sciences	
General Medicine, Human	14	Astrogration	48
Psychology, Human	33	Astronautics	23
Klinton	13	Astronomy	34
Negotiation/Diplomacy	59	Astrophysics	36
Personal Combat, Unarmed	30	Starship Combat Strategy/Tactics	36
Physical Sciences		Starship Helm Operation	31
Mathematics	26	Starship Sensors	52
Physics	34	Starship Weaponry Operation	19
Planetary Sciences, Meteorology	12	Streetwise	39
Planetary Survival, Tropical	37	Transporter Operation Procedures	43
Security Procedures	17	Warp Drive Technology	27
Small Equipment Systems Operation	28	Zero-G Operations	15
Small Equipment Systems Technology	26		

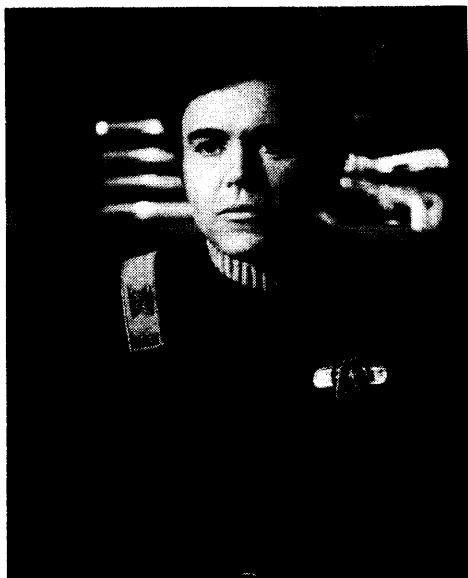

Name: SCOTT, Montgomery
Rank: Commander
Serial No.: SE197 - 514
Current Assignment: Galaxy Exploration Command, USS Enterprise, NCC - 1701
Position: Chief Engineer
Race: Human **Age:** 60
Birthplace: Terra/Scotland **Sex:** Male

STR - 60 CHA - 62
 END - 55 LUC - 71
 INT - 91 PSI - 22
 DEX - 65

To-Hit Modern: 63 Bare-Hand Damage: 1D10 + 10
 HTH: 70 AP - 10
 Claymore: 41

Significant Skills: Skill	Rating
Administration	42
Artistic Expression, Bagpipes	56
Carousing	72
Communication Systems Operation	27
Communication Systems Technology	42
Computer Operation	52
Computer Technology	56
Damage Control Procedures	89
Deflector Shield Operation	35
Deflector Shield Technology	46
Electronics Technology	78
Environmental Suit Operation	34
Instruction	46
Language, Gaelic	48
Leadership	55
Life Sciences, Biology	10

Life Support Systems Technology	65	Federation Law	36
Marksmanship, Modern Weapon	61	Space Sciences	
Mechanical Engineering	79	Astronomy	32
Medical Sciences, Gen. Med., Human	14	Astrophysics	32
Negotiation/Diplomacy	33	Astronautics	99
Personal Combat, Claymore	16	Starship Combat Strategy/Tactics	33
Personal Combat, Unarmed	76	Starship Helm Operation	28
Personal Weaponry Technology	42	Starship Sensors	33
Physical Sciences		Starship Weaponry Operation	11
Mathematics	68	Starship Weaponry Technology	42
Physics	62	Streetwise	48
Planetary Survival, Cool Temperate	15	Transporter Operation Procedures	81
Security Procedures	36	Transporter Systems Technology	94
Shuttlecraft Pilot	38	Trivia, Alcoholic Beverages	89
Shuttlecraft Systems Technology	69	Warp Drive Technology	97
Small Equipment Systems Operation	45	Zero-G Operations	35
Small Equipment Systems Technology	45		
Social Sciences			
Federation History	32		

Name: CHEKOV, Pavel Andreievich
Rank: Commander
Serial No.: SN2304-0121
Current Assignment: Galaxy Exploration Command, USS Reliant, NCC - 1864
Position: First Officer
Race: Human **Age:** 37
Birthplace: Terra/Russia **Sex:** Male

STR - 64 CHA - 81
 END - 59 LUC - 60
 INT - 81 PSI - 11
 DEX - 68

To-Hit Modern: 57 Bare-Hand Damage: 1D10 + 5
 HTH: 55 AP - 10

Significant Skills: Skill	Rating
Administration	40
Carousing	30
Communication Systems Operation	23
Computer Operation	48
Computer Technology	23
Damage Control Procedures	47
Deflector Shield Operation	42
Deflector Shield Technology	25
Electronics Technology	22
Environmental Suit Operation	27
Gaming	16
Instruction	20
Language	
Vulcan	15
Russian	46
Leadership	52

Life Sciences		Social Sciences	
Botany	27	Federation History	41
Ecology	32	Federation Law	39
Exobiology	21	Political Science	22
Zoology	26	Space Sciences	
Life Support Systems Technology	16	Astrostation	79
Marksmanship, Modern Weapon	47	Astronautics	24
Medical Sciences, Gen. Med., Human	13	Astronomy	81
Negotiation/Diplomacy	43	Astrophysics	81
Personal Combat, Unarmed	43	Starship Combat Strategy/Tactics	52
Physical Sciences		Starship Helm Operation	35
Mathematics	45	Starship Sensors	57
Physics	23	Starship Weaponry Operation	68
Planetary Sciences, Geology	12	Starship Weaponry Technology	36
Planetary Survival, Warm Temperate	23	Streetwise	11
Security Procedures	26	Transporter Operation Procedures	17
Shuttlecraft Pilot	25	Warp Drive Technology	39
Small Unit Tactics	22	Zero-G Operations	21

Name: RAND, Janice
Rank: Lieutenant/Commander
Serial No.: SV8100 - 222
Current Assignment: Galaxy Exploration Command, USS Enterprise, NCC - 1701
Position: Transporter Operator
Race: Human **Age:** 41
Birthplace: Terra **Sex:** Female

STR - 52 CHA - 71
 END - 56 LUC - 20
 INT - 69 PSI - 45
 DEX - 68

To-Hit Modern: 54 Bare-Hand Damage: 1D10 + 4
 HTH: 45 AP - 10

Significant Skills: Skill	Rating
Administration	69
Artistic Expression, Vocal Music	53
Carousing	29
Communication Systems Operation	33
Communication Systems Technology	12
Computer Operation	42
Damage Control Procedures	43
Electronics Technology	48
Environmental Suit Operation	16
Gaming	38
Instruction	49
Language, French	10

Leadership	28	Planetary Survival, Arctic	31
Life Sciences		Security Procedures	21
Ecology	16	Social Sciences	
Exobiology	23	Federation History	52
Marksmanship, Modern Weapon	40	Federation Law	41
Mechanical Engineering	26	Space Sciences	
Medical Sciences		Astrostation	30
General Medicine, Human	14	Astronomy	32
Psychology, Human	21	Astrophysics	39
Negotiation/Diplomacy	32	Starship Helm Operation	22
Personal Combat, Unarmed	28	Starship Sensors	32
Personal Weaponry Technology	5	Streetwise	14
Physical Sciences		Transporter Operation Procedures	83
Mathematics	37	Transporter Systems Technology	41
Physics	41	Zero-G Operations	10

Name: TERRELL, Clark
Rank: Captain
Serial No.: SC1373-6189C
Current Assignment: Galaxy Exploration Command, USS Reliant, NCC - 1864
Position: Commanding Officer
Race: Human **Age:** 42
Birthplace: Terra **Sex:** Male

STR - 63 CHA - 63
 END - 56 LUC - 28
 INT - 61 PSI - 43
 DEX - 58

To-Hit Modern: 59 Bare-Hand Damage: 1D10 + 9
 HTH: 62 AP - 9

Notes: Committed suicide.

Significant Skills: Skill	Rating
Administration	46
Carousing	47
Communication Systems Operation	30
Computer Operation	72
Computer Technology	22
Damage Control Procedures	27
Deflector Shield Operation	44
Electronics Technology	44
Environmental Suit Operation	53
Instruction	28
Language, Orion	20
Leadership	54

Life Sciences, Ecology	54	Space Sciences	
Marksmanship, Modern Weapon	60	Astrostation	70
Medical Sciences		Astronautics	27
General Medicine	15	Astronomy	54
Psychology, Human	23	Astrophysics	64
Negotiation/Diplomacy	55	Starship Combat Strategy/Tactics	67
Personal Combat, Unarmed	66	Starship Helm Operation	42
Planetary Sciences, Geology	12	Starship Sensors	59
Planetary Survival	29	Starship Weaponry Operation	50
Security Procedures	12	Streetwise	15
Shuttlecraft Pilot	32	Transporter Operation Procedures	31
Social Sciences		Warp Drive Technology	25
Federation History	42	Zero-G Operations	28
Federation Law	44		



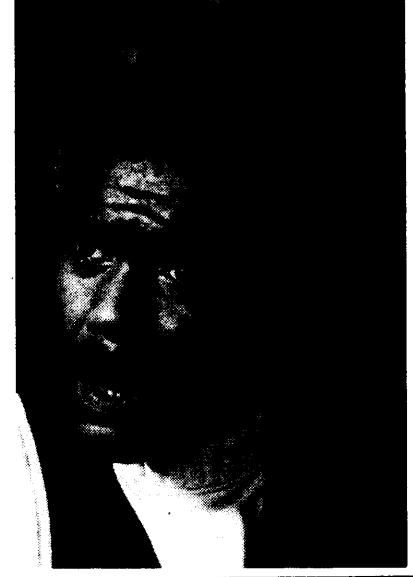
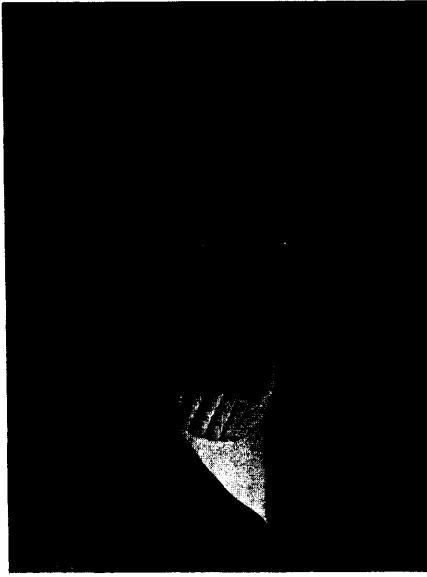
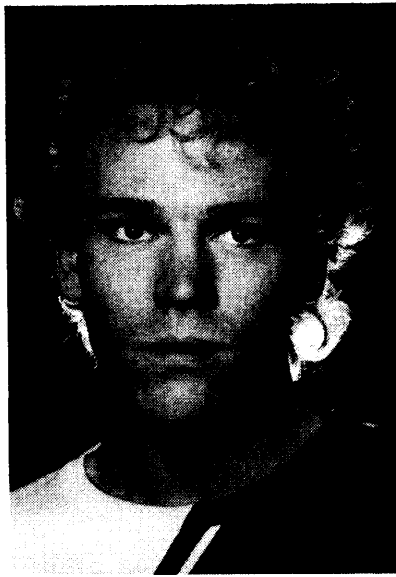

Name: SAAVIK
Rank: Lieutenant
Serial No.: SN38734-8402
Current Assignment: Galaxy Exploration Command, USS Enterprise, NCC-1701
Position: Navigator
Race: Vulcan/Romulan **Age:** 25
Sex: Female
Birthplace: Vulcan colony world, now abandoned.

STR - 80 CHA - 60
 END - 70 LUC - 43
 INT - 66 PSI - 62
 DEX - 61

To-Hit Modern: 53 Bare-Hand Damage: 2D10 + 6
 HTH: 62 AP - 10

Significant Skills:	Rating
Administration	41
Carousing	31
Communication Systems Operation	18
Computer Operation	55
Computer Technology	12
Damage Control Procedures	19
Deflector Shield Operation	36
Electronics Technology	14
Environmental Suit Operation	23
Gaming	22
Instruction	39
Language	
Romulan	86

Vulcan	94	Space Sciences	
Leadership	47	Astrogration	52
Marksmanship, Modern Weapon	45	Astronomy	61
Negotiation/Diplomacy	33	Astrophysics	73
Personal Combat, Unarmed	64	Starship Combat Strategy/Tactics	46
Physical Sciences		Starship Helm Operation	31
Mathematics	46	Starship Sensors	42
Physics	28	Starship Weaponry Operation	22
Planetary Survival	24	Streetwise	92
Security Procedures	15	Transporter Operation Procedures	26
Shuttlecraft Pilot	31	Water Vehicle Operation	28
Social Sciences		Zero-G Operations	23
Federation History	37		
Federation Law	38		

Name: MARCUS, David (Ph.D.)
Rank: Associate Research Scientist
Serial No.: RSX2642-5486BFD
Current Assignment: Office Of Research And Exploration, Regular One Deep Space Research Station
Position: Assistant Project Director
Race: Human **Age:** 22
Sex: Male
Birthplace: Terra

STR - 63 CHA - 54
 END - 61 LUC - 61
 INT - 68 PSI - 26
 DEX - 59

To-Hit Modern: 29 Bare-Hand Damage: 1D10 + 7
 HTH: 49 AP - 9

Significant Skills:	Rating
Administration	39
Communication Systems Operation	21
Communication Systems Technology	17
Computer Operation	64
Computer Technology	48
Electronics Technology	38
Environmental Suit Operation	14
Gaming	39
Instruction	42

Life Sciences		Personal Combat, Unarmed	39
Botany	31	Physical Sciences	
Ecology	82	Chemistry	37
Exobiology	48	Mathematics	69
Genetics	72	Physics	79
Zoology	49	Planetary Sciences	
Life Support Systems Technology	35	Geology	35
Mechanical Engineering	26	Hydrology	41
Medical Sciences		Meteorology	40
General Medicine, Human	21	Oceanography	46
Negotiation/Diplomacy	08	Transporter Operation Procedures	26

Name: CHAPEL, Christine, M.D.
Rank: Lt. Commander
Serial No.: SM3561-9943
Current Assignment: Galaxy Exploration Command, USS Enterprise, NCC-1701
Position: Medical Officer
Race: Human **Age:** 46
Sex: Female
Birthplace: Terra

STR - 59 CHA - 73
 END - 53 LUC - 31
 INT - 68 PSI - 39
 DEX - 71

To-Hit Modern: 47 Bare-Hand Damage: 1D10 + 4
 HTH: 49 AP - 11

Significant Skills:	Rating
Administration	53
Carousing	29
Communication Systems Operation	20
Computer Operation	43
Damage Control Procedures	10
Electronic Technology	11
Environmental Suit Operation	16
Instruction	54
Language, Vulcan	25
Leadership	44
Life Sciences	
Bionics	47
Botany	84
Ecology	68
Exobiology	34

Genetics	46	Mathematics	27
Zoology	70	Physics	21
Life Support Systems Technology	38	Planetary Sciences, Geology	10
Marksmanship, Modern Weapon	23	Planetary Survival, Cool Temperate	23
Medical Sciences		Small Equipment Systems Operation	24
General Medicine, Human	54	Social Sciences	
Vulcan	42	Federation History	33
Pathology	41	Federation Law	31
Psychology, Human	47	Space Sciences	
Vulcan	33	Astrogration	11
Klingon	13	Astronomy	19
Surgery	48	Astrophysics	14
Negotiation/Diplomacy	51	Starship Sensors	31
Personal Combat, Unarmed	28	Streetwise	13
Personal Weapons Technology	5	Transporter Operation Procedures	10
Physical Sciences		Trivia, Vulcan Cooking	31
Chemistry	37	Zero-G Operations	12

Name: MORROW, Randolph E.
Rank: Flag Admiral
Serial No.: SC877-9263CAC
Current Assignment: Star Fleet Headquarters Command
Position: Commander, Quadrant 0
Race: Human **Age:** 59
Sex: Male
Birthplace: Terra

STR - 65 CHA - 66
 END - 54 LUC - 42
 INT - 81 PSI - 01
 DEX - 68

To-Hit Modern: 55 Bare-Hand Damage: 1D10 + 8
 HTH: 53 AP - 10

Significant Skills:	Rating
Administration	81
Carousing	21
Communication Systems Operation	37
Computer Operation	89
Computer Technology	27
Damage Control Procedures	31
Deflector Shield Operation	21
Environmental Suit Operation	29
Gaming	66
Ground Vehicle Operation	52
Instruction	61
Language, Andorian	49
Leadership	72

Marksmanship, Modern Weapon	42	Space Sciences	
Medical Sciences		Astrogration	62
General Medicine, Human	16	Astronautics	11
Psychology, Human	24	Astronomy	42
Negotiation/Diplomacy	61	Astrophysics	36
Personal Combat, Unarmed	38	Sports, Handball	56
Physical Sciences		Starship Combat Strategy/Tactics	66
Mathematics	33	Starship Helm Operation	42
Physics	41	Starship Sensors	28
Planetary Survival	18	Starship Weaponry Operation	27
Security Procedures	41	Streetwise	59
Shuttlecraft Pilot	24	Transporter Operation Procedures	33
Social Sciences		Warp Drive Technology	19
Federation History	77	Zero-G Operations	41
Federation Law	63		
Political Science	18		



Name: STILES, Lawrence
Rank: Captain
Serial No.: SC1688-8992CEC
Current Assignment: Military Operations Command, USS *Excelsior*, NX - 2000
Position: Commanding Officer
Race: Human **Age:** 34
Birthplace: Republic of Mars **Sex:** Male

STR - 67 CHA - 39
 END - 69 LUC - 55
 INT - 81 PSI - 07
 DEX - 62

To-Hit Modern: 66 Bare-Hand Damage: 1D10 + 9
 HTH: 63 AP - 10

Significant Skills:

Skill	Rating
Administration	41
Carousing	12
Communication Systems Operation	33
Communication Systems Technology	15
Computer Operation	77
Computer Technology	12
Damage Control Procedures	44
Deflector Shield Operation	28
Deflector Shield Technology	12
Environmental Suit Operation	33
Gaming	19
Instruction	57
Language, Tellarite	28
Leadership	84
Life Support Systems Technology	15
Marksmanship, Modern Weapon	69
Medical Sciences	
Psychology, Human	24
Negotiation/Diplomacy	52
Personal Combat, Unarmed	64
Personal Weapons Technology	17
Physical Sciences	
Mathematics	33
Physics	27
Planetary Survival	40
Security Procedures	61
Shuttlecraft Pilot	48
Small Unit Tactics	43
Social Sciences	
Federation History	60
Federation Law	49
Space Sciences	
Astrogation	77
Astronautics	31
Astronomy	61
Astrophysics	47
Starship Combat Strategy/Tactics	84
Starship Helm Operation	69
Starship Sensors	38
Starship Weaponry Operation	32
Streetwise	88
Transporter Operation Procedures	53
Warp Drive Technology	19
Zero-G Operations	69

Name: MARCUS, Carol (Ph.D.)
Rank: Senior Research Scientist
Serial No.: RSX1738-9458RND
Current Assignment: Office Of Research And Exploration *Regula One* Deep Space Research Station
Position: Project Director
Race: Human **Age:** 48
Birthplace: Terra **Sex:** Female

STR - 54 CHA - 68
 END - 50 LUC - 63
 INT - 71 PSI - 29
 DEX - 62

To-Hit Modern: 31 Bare-Hand Damage: 1D10 + 6
 HTH: 31 AP - 10

Significant Skills:

Skill	Rating
Administration	51
Communication Systems Operation	29
Computer Operation	38
Damage Control Procedures	17
Electronics Technology	20
Instruction	42
Leadership	39
Life Sciences	
Botany	42
Ecology	69
Exobiology	41
Genetics	96
Zoology	44
Medical Sciences	
General Medicine, Human	23
Pathology	23
Negotiation/Diplomacy	51
Physical Sciences	
Chemistry	39
Mathematics	70
Physics	81
Planetary Sciences	
Geophysics	22
Geology	37
Hydrology	44
Meteorology	32
Transporter Operation Procedures	21

Name: SINGH, Khan Noonian
Race: Human (genetically improved) **Age:** Unknown
Birthplace: Terra **Sex:** Male

STR - 91 CHA - 99
 END - 104 LUC - 56
 INT - 96 PSI - 62
 DEX - 98

To-Hit Modern: 49 Bare-Hand Damage: 2D10 + 11
 HTH: 84 AP - 13

Notes: Eugenics Wars tyrant; absolute ruler of half of Earth from 1992 to 1996; escaped Earth aboard "*Botany Bay*" sleeper ship; exiled to Ceti Alpha V (After being awakened by crew of U.S.S. *Enterprise*) for attempted hijacking of a Federation vessel; successfully hijacked U.S.S. *Reliant* and stole Genesis Device; killed in Device detonation

Significant Skills:

Skill	Rating
Administration	71
Communication Systems Operation	24
Computer Operation	42
Deflector Shield Operation	11
Environmental Suit Operation	53
Leadership	98
Medical Sciences	
Psychology, Human	84
Negotiation/Diplomacy	67
Personal Combat, Unarmed	69
Planetary Survival	99
Social Sciences	
Political Science	52
Terran Law	72
Starship Combat Strategy/Tactics	59
Starship Helm Operation	35
Starship Weaponry Operation	21
Transporter Operation Procedures	41

Name: KLUGE
Rank: Captain
Current Assignment: Klingon *Bird Of Prey*
Position: Commanding Officer
Race: Imperial Klingon **Age:** 39
Birthplace: Klinzhai, Klingon Empire **Sex:** Male

STR - 69 CHA - 30
 END - 57 LUC - 14
 INT - 67 PSI - 01
 DEX - 71

To-Hit Modern: 56 Bare-Hand Damage: 1D10 + 8
 HTH: 50 AP - 11

Significant Skills:

Skill	Rating
Administration	35
Clandestine Operations	24
Communication Systems Operation	11
Computer Operation	39
Computer Technology	10
Electronics Technology	10
Gaming	12
Interrogation	53
Language, Galacta	30
Leadership	76
Marksmanship, Modern Weapon	41
Medical Sciences	
Psychology, Klingon	63
Negotiation/Diplomacy	13
Planetary Survival	42
Security Procedures	48
Shuttlecraft Pilot	32
Small Unit Tactics	49
Social Sciences	
Klingon Law	30
Federation Law	10
Klingon Culture/History	10
Space Sciences	
Astrogation	54
Astronomy	34
Astrophysics	36
Starship Combat Strategy/Tactics	71
Starship Helm Operation	50
Starship Sensors	20
Starship Weaponry Operation	15
Streetwise	61
Surveillance	77
Warp Drive Technology	30

Notes: Killed during Genesis Planet incident.

LOST AND PRESUMED DEAD

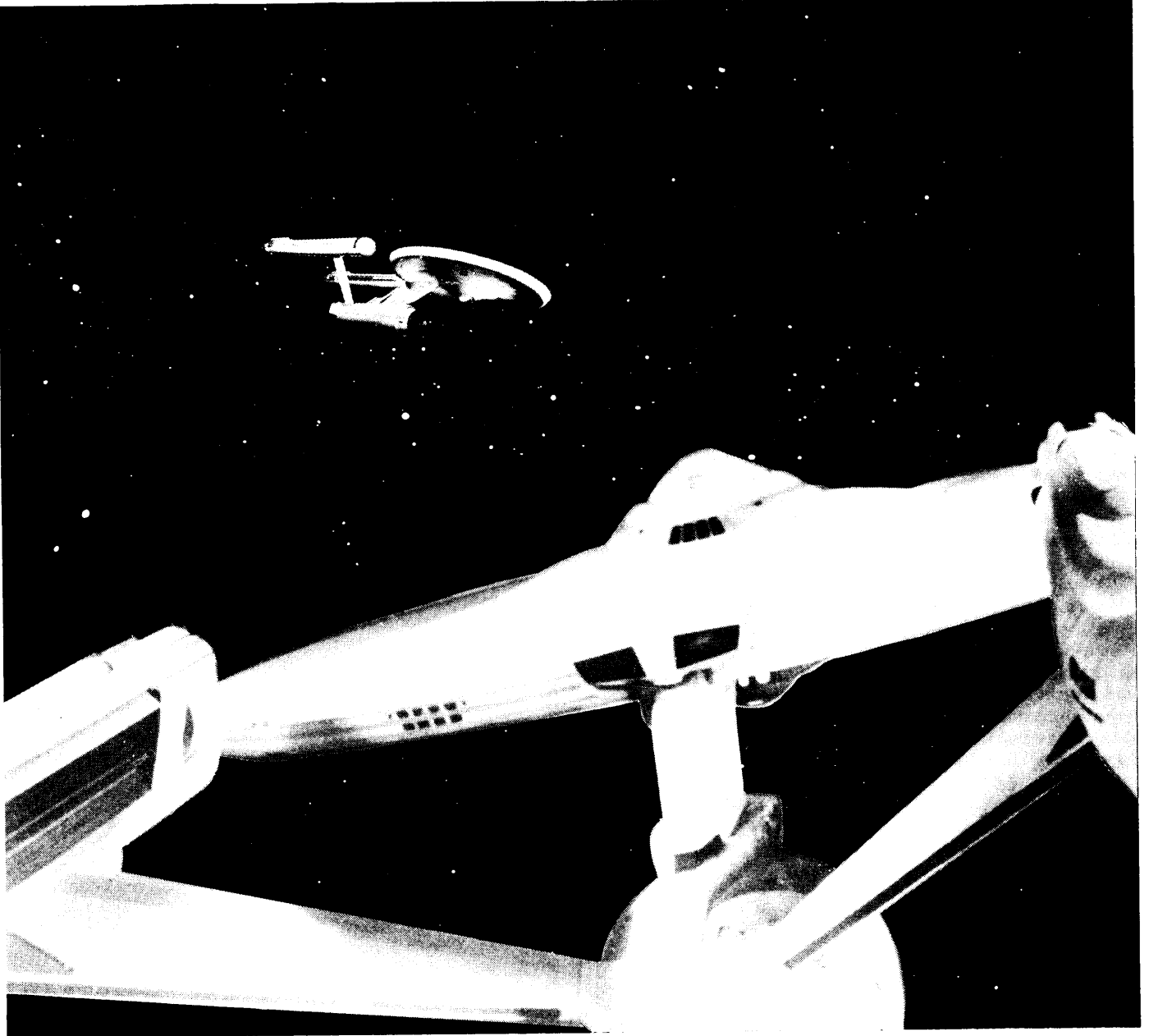

By Greg K. Poehlein

This adventure is designed to be played with **STAR TREK: The Role Playing Game** and this supplement. Adventurers are assumed to be officers aboard an *Enterprise* class heavy cruiser, but any major Star Fleet vessel may be used as the basis for this scenario.

The adventure takes place in an unoccupied fringe area of the Federation, and well away from either the Klingon Empire or the Romulan Star Empire. On routine patrol, when the player characters' vessel investigates a distress call, they find the long-lost *USS Republic* with ship and crew intact. According to the *Republic's* Captain, his Edoan Science Officer went insane and wiped vital navigational data from the ship's computer memory. Unable to find their way back across a huge stellar void to Federation space, the *Republic's* crew requests help.

All is not as it seems, which the players discover when they find the clues left in the computer by the supposedly mad officer. The *Republic's* crew has been infected by a strain of flying parasites that control them. The parasites have set a trap for the player characters that may leave them under the control of the parasite mass-mind as well.

The characters must avoid being infected, and either retake the ship from the infected crew or find a way to drive out the infection without killing all aboard. Otherwise, their own ship may be forced to destroy them along with the *Republic* to stop the insidious parasite plague.

Playtesters

Kimberly Guinn, Doug Kemmerer, Terri Klingelhoef, Wilda Klingelhoef, Jeff Lockridge, Guy W. McLimore, Jr., Carlynn Nugent.

THE ADVENTURE

ROUTINE PATROL

Captain's Log – Stardate 8097.3: Captain Preye (or your captain's name here) reporting. Excalibur on routine patrol along edge of the area known as the Styx Rift. We are twenty days out of Cerberus and proceeding at Warp 4. All systems functioning normally.

The players should be informed that they are either patrolling or mapping the Styx Rift, an area unusually devoid of stars or systems. This area, which does have a few scattered systems, is on the border of Federation Space nearest the star system of Cerberus. Conditions in the Rift itself hamper communication, though they do not make it impossible. Magnetic fields and clouds of interstellar gas prevent the transmission of subspace messages for long distances, and so the ship is essentially out of communication with any Star Base or other installation.

At this point, the ship's Communications Officer begins receiving a very faint distress signal. A quick triangulation on the source of the signal (neither of which will require a save on the character's Communications Systems Procedures skill, though the gamemaster may ask for such a roll just to confuse matters, giving the interference as a reason) will show that the signal is coming from the heart of the Rift, about 10 days distant at Warp 8.

The gamemaster can give an additional message if players look for more signals beyond the basic distress call; if not, they should be allowed to rush blindly in without the benefit of prior knowledge. If the players do not look, and the gamemaster wishes, he may require the Communications Officer to make a successful Skill Roll against his rating in *Communication Systems Operation*. With a successful roll, he can determine that the SOS is accompanied by a repeating voice signal. The additional message reads:

"This is the Federation starship *USS Republic*. We have lost all navigational function and are unable to return to known space. Please send help immediately."

If the players request information on the *Republic* from the library computer, they will find that she was assigned to mapping duty in the Rift area and failed to return. She is officially listed as lost on Reference Stardate 2/0808.26, approximately fifteen years before the current mission.

APPROACHING THE *USS REPUBLIC*

After 10-days travel in the direction of the message, the Science Officer will notice a sensor blip, which will prove to be a *Constitution* class heavy cruiser. It will be about five minutes before visual contact is possible. The players may wish to stop and gather data before proceeding onward. Again, the gamemaster should not tell the players this; they must think of these things themselves. No attempt to determine more about the blip, will prevent the players from learning the information below until they come within visual range.

A routine sensor scan will indicate that the blip is, in fact, the *Republic*, moving at Warp 2, apparently on course to a nearby star. It has no noticeable damage and approximately 400 humanoids aboard. Further scans will indicate that it is operating at full power, even after 15 years! Sensors also will show that the player's ship is NOT being scanned

in return, contrary to standard Federation policy. The players would realize that, given stops to gather sufficient raw materials, it is possible to manufacture and/or capture enough antimatter to keep limited engine power for that long a period if necessary, and that a ship even could have collected enough material to keep the food synthesizers supplied.

HAILING THE *REPUBLIC*

Until summoned by subspace radio, only the repeated SOS is being broadcast. When the Communications Officer hails the *Republic*, the SOS will stop immediately, but a reply will take several minutes. When it does come, it will be an audio-visual signal. The face on the screen belongs to a forty-five year old officer in an old-style uniform, who identifies himself as Capt. Richard Masterson.

Tell the crew his approximate age, but don't tell them how old he actually should be. This information, a clue to the adventure, is available only if the players call up a crew roster on the *Republic*. If the players request this, give them the primary officers' names, ranks, and other important information. Include Chief Science Officer Xepesna instead of Asst. Science Officer Rodriguez, another clue. If they have not already requested it, tell them that the *Republic*, exploring the Rift, was presumed lost 15 years ago.

In the following exchange, Capt. Masterson will seem slightly disoriented, and will exhibit a small, though not too pronounced, delay in making decisions. At first, he will be startled by the players' odd uniforms. (He is wearing the uniform from the television series and has never seen the new style uniforms.) He will state that his ship has been cruising in this area for quite a while (he won't volunteer any definite times) because the ship's astrogation memory banks have been wiped clean. Without stellar navigation data, he explains, he has found it impossible to navigate with any success in the relatively starless Rift. He will request back-up astrogation data to insert into his own computer.

He will then invite the ranking officers to board the *Republic*. He will suggest that the Captain lead the beam-over, unless he is an Edoan, when he will suggest that the Science Officer lead the beam-over party instead. He will not do this in a suspicious way, nor will he give any indication that the Captain is unwelcome if he/she wants to beam over, too.

If the players called for the personnel files on the *Republic*, they will certainly be a bit startled by the appearance of her officers, at least as seen through the view-screen. Though the *Republic* has been lost about 15 years, everyone appears to be about the same age listed in their personnel files. If these records have been read, it will be readily noticed that the officers appear to be the ages listed as of the time the ship was declared lost. No solid explanation for this will be given, if requested, except some vague notions about "time-dilation effect."

At this point, the players may choose between three responses to the request for astrogation data and two responses to the invitation to beam aboard the *Republic*; this gives the following 6 possibilities, with the indicated responses. In any of the first three responses, if anything should happen to the players before the as-yet-unrevealed menace is resolved, the *Republic* could head back toward the Federation with its deadly cargo! In any of the last three responses, the player characters will be spared direct confrontation with

the parasites, but the problem of the *Republic* has not been solved. The 6 possibilities are:

1. They may accept the situation at face value, agreeing to provide the requested data and beam aboard. Masterson will take the data, send it off with his Science Officer, and proceed with the rest of the adventure.
2. They may be non-committal about the data and agree to beam aboard. If this is done, Masterson will be somewhat upset that they didn't bring the data with them, but will quickly come to the conclusion that it is a misunderstanding rectifiable later, and the adventure will proceed.
3. They may refuse outright to provide the data, but indicate that they will beam across. In this case, Masterson will insist for a few minutes that they bring the data with them, but will give in, if necessary, and the adventure will proceed.
4. They may decline the invitation to beam aboard, but provide the requested data without question. Capt. Masterson will thank them and proceed back to the Federation, with his dangerous cargo intact and undiscovered. This problem may eventually see a solution, but the players may be considered to have lost the scenario, and some other crew will have to save the day.
5. They may decline to beam across and be non-committal about the data. This is a waiting pattern that will be broken of its own when Capt. Masterson realizes that the player characters do not intend to send the data across.
6. They may refuse the request to provide the data as well as the invitation to beam aboard. Capt. Masterson will continue to request either the data or the opportunity to follow the player's ship back. The players will soon realize that the only *sure* way to keep the *Republic* from following them back is to stay where they are.

BEAM OVER

The player characters will be beamed over into Transporter Room 1. Present are Capt. Masterson, Asst. Science Officer Juliet Rodriguez, Chief Security Officer Samuel Rodriguez, and Chief Engineer Bahrrr. Masterson will welcome the guests heartily. During this time, if any Edoan crewmen have beamed aboard, the Captain will invent an errand that will take them back to the players' ship. He will do this in a manner that would not create suspicion, if possible.

Foremost on the Captain's mind is the astrogation data, and he will address this topic immediately. If the players have brought the requested astrogation data with them, it will be turned over to Science Officer Rodriguez, who will excuse herself and leave the room quickly; if not, Rodriguez will excuse herself anyway, claiming other pressing duties. Then, the Captain will engage his guests in small talk, asking more about their uniforms, changes in Star Fleet and the Federation, and the like.

At some point in the conversation, either in answer to a question or merely volunteering the information, Captain Masterson will tell the player characters that his Chief Science Officer, Xepesna, went mad, locked herself in the computer core area, wiped the information, and then killed herself.

Just as he finishes this story, Rodriguez will call him on the intercom, requesting his presence on the bridge. Masterson will excuse himself, politely refusing any requests to accompany him to the bridge. (This should make the characters suspicious.) As he leaves, he will offer to have Security Officer Rodriguez show them around, suggesting that they first see the computer core area and then Sick Bay, both on this deck.

THE TOUR OF THE SHIP

Should the players agree to a tour, Rodriguez alone will lead them, neither watching them closely nor paying particular attention to their discussions, as long as they are not too overt. The player characters will be led first to the computer core and then to Sick Bay. If they ask to see something else first, Rodriguez will agree, but he will take them to the computer core anyway, saying that it is "on the way." If the players insist, Rodriguez will show the characters anything they wish to see, except for the bridge and engineering areas.

It is a good idea to have the players make a Saving Roll here without telling them what it will be used for. Compare each character's roll against his INT score. If any roll is successful, proceed with the trip to the computer core, but during the description, secretly tell the successful players that they have a strange feeling that something is not right. If the uneasy characters communicate their feeling through discussion, allow any players who make *immediate* requests to determine what is wrong by making a second Saving Roll. Then roll again against INT, but do not tell the players this. A successful roll will cause the player character to notice that there is not a single crewman in any of the corridors! (Anyone having seen at least two or three episodes of the TV series will recall that there was always someone in the corridors.)

IN THE COMPUTER CORE

When the player characters enter the Computer Core, they will see nothing amiss. There is no visible damage, indicating that the data was purged from a keyboard, and not by smashing any equipment. If any of them desire, the characters could request information from the computer.

If any character calls up information from the library computer at this time, or at any other time during this adventure, it should be provided. The only information specific to this adventure is recorded under the headings listed below. It is detailed in the **Background Information** section, but it should be given to the players only if they request the specific data.

Pertinent Computer Records

- astrogation data
- planetary data
- Captain's log entries
- Science Officer's log entries
- personnel information
- recreational tapes

RESUMING THE TOUR

After the characters are finished in the computer room, Rodriguez will suggest that they walk by the sick bay, especially if one of them is a Medical Officer. Once again, the characters will be led through deserted corridors. If they have not already done so, give them a second chance to notice that something seems strange, as well as a second chance to determine that the strangeness comes from the deserted corridors.

The characters will be led into Sick Bay, which is empty and appears to be in order. Rodriguez will leave them, saying that Dr. T'Narra, the Medical Officer, seems to have just stepped out, but surely will be with them soon.

SICK BAY

There will be time for the player characters to gain access to the computer, before Dr. T'Narra returns. If they call up the autopsy report on Xepesna, they will find out that no autopsy was performed. A report of her death will list the cause of death as suicide, and state that the body was buried in deep space. When activated, the console will display a menu that contains the items in the following list. The entries indicated in *italics* contain information pertinent to this adventure. These may be found in the **Background Information** section. If they desire to do so, the characters should be allowed to track down the clues and discover the messages hidden for them in the library computer files.

Sick Bay Computer Console Listing

Diagnostic Program

Treatment Log

Personnel Files

Death Reports and Autopsies

Medical Supplies

THE FLYING MENACE

Dr. T'Narra will come in from the adjoining room. She will ask that the characters accompany her, and will conduct them to the next room, stepping back to allow them to enter first. As soon as the door is open, a flying parasite will detach itself from the wall opposite the door and fly toward the characters. Dr. T'Narra will hold the door open, and the parasite will fly from the room, trying to attach itself to a player character's back. Its description is given in the **Background Information** section.

Choose the target at random. The To-Hit Number for the parasite and all others in this one encounter is 37. This is half the DEX score of 115, with a penalty of 20 because the parasites are still a bit sluggish.

Ideally, only one of the creatures should attack the characters as they enter the sick bay wardroom. This attack likely will be successful, with a parasite attaching itself to one player character. If the players are quick and clever, however, they should be able to retreat and close the door before other parasites become active and attack. Quick action will save the player character, even if the parasite's attack was successful, by dislodging the parasite before it has a chance to inject the parasitic material.

Furthermore, quick reflexes should allow them to shove T'Narra aside, close the door, and jam it so that only one flying parasite can attack. There are many other parasites in the room, but they will seem lethargic and will not immediately attack even if the player characters do not flee. The parasites will wake up at a rate of 1 per combat turn until 15 or so are active.

THE DECISION

As the combat comes to an end, the *Republic* will shudder once. Each character's communicator will beep at the same time. The player characters' own ship will inform them that the *Republic* has raised her shields and opened fire upon them, effectively leaving them stranded!

The characters must make a decision that will affect the rest of the scenario and probably their lives as well. They may resign themselves to their fate and order their own ship to destroy the *Republic*. With an *Enterprise* class heavy cruiser, it would be simply a matter of time before the *Republic* (a *Constitution* class ship) is reduced to debris.

The stranded characters may, however, decide to take a more active role in concluding this episode. They will know that, with the *Republic's* shields up, transporting is impossible. They likely will realize, perhaps with some cautious prodding from the gamemaster, that the only way they can effectively leave the *Republic* is to make their way to the shuttlecraft hangar, steal a shuttle, and return to their own ship while it battles the *Republic*. They may decide to make this escape, or they may try to take control of the *Republic*, hoping to end the battle. They even might decide to destroy the parasites. These three possibilities are discussed in the sections **Stealing A Shuttle**, **Seizing The Bridge**, and **Destroying The Menace**.

Whatever their plan, the player characters will have difficulties. They will have no trouble leaving Sick Bay, but the turbolifts have been shut down, forcing them to use the stairways. The escape attempt can be played out on FASA's deck plans of the *USS Enterprise*, which is identical in plan to the *Republic*. It also may be played abstractly, without specific maps.

The player characters should have several encounters with groups of Republic crewmen sent to stop them. These groups may be made up of the generic crewmen listed as The Extras in the **Cast Of Characters** section. The groups should be about the same size as the escaping party. They will not use weapons, but will attack hand-to-hand, attempting to disarm the player characters and render them unconscious. If they are armed, the player characters will probably have little trouble with these groups, but they will prove an annoyance. The section on **Playing Infected Crewmen** should be used to judge these encounters.

The player characters also should have several encounters with flying parasites, in groups of three or four. These encounters will be more dangerous, as one successful attack by a parasite will leave the victim under the parasite's control. The section on **Combat With The Parasites** should be used to judge these encounters.

STEALING A SHUTTLE

Once the player characters reach the hangar deck, their hopes of escape will be dashed. They will discover that the hangar doors have been sealed from the bridge and will not open. They likely will try various methods to override this command. For each of these, the appropriate Skill Rolls should be made; all will fail, but the players should not know this initially. In these attempts, they may discover that the parasite-infected crewmen have taken the precaution of manually disabling the door mechanism, but they will not be able to do anything about it in any reasonable time.

SEIZING THE BRIDGE

If the player characters attempt to break into the bridge, they will have to deal with the officers and crewmen there. This combat should be judged using the section on **Combat With Infected Crewmen**.

Once victorious, the player characters will be faced with the dilemma of whether to vacate the ship and then destroy it, or try to save all the crew, if possible. They won't have much time to make this decision, because the *Republic* crewmen will begin storming the bridge five 10-second turns after the bridge crew has been dealt with. This gives the player characters time to seal off the bridge, if they think of it.

If they decide to beam off, they may contact their own ship easily, assuming that they somehow convince their own crew members that this is not a trick. The *Republic* may then be destroyed by several well-placed photon torpedoes. This would be a rather unsatisfactory solution, in that although the crisis is averted, a valuable starship and innocent crew is lost in the process.

If the players wish to try to save the *Republic* crew, see the section **Destroying the Menace**.

DESTROYING THE MENACE

If one or more of the characters have recognized the parasites, they may attempt to destroy them. This may come about in several ways. First, the players themselves may remember the TV episode *Operation: Annihilate!* and the parasites there. Second, one of the players may have stated that his character served aboard the *Enterprise* or with one of the top officers from the *Enterprise* and thus have heard about the earlier encounter. Third, the players may think to access the *Republic's* computer files for information about flying parasites in general.

If the players remember the parasites from the TV episode, assume that their characters have been told about the incident at one time or another. If any player character has served aboard the *Enterprise* or with one of her top officers, he automatically knows about the *Enterprise's* encounter with flying parasites, and the player should be given the data about the incident. If any player character makes a general search for information, giving the computer a basic description of the creatures, the player should be required to make a Skill Roll against his rating in *Computer Operation* averaged with his rating in *Exobiology*; if he is successful, then give him the data on the *Enterprise's* encounter. If a more specific search is made, then the Skill Roll should be made only against the rating in *Computer Operation*. The data about the *Enterprise's* encounter is given in the **Library Files** section.

Characters with access to the information about the first batch of parasites will know that they were dispatched by ultraviolet light. They will find two portable UV lights in the medical lab, where they are used for sterilization. These will not be strong enough to stop the parasites, nor will they injure or free an infected character from the parasites. They will, however, keep the flying parasites at bay, and will cause an infected character to shy away. (Imagine Dracula shying away from a cross.) In a combat situation, the characters with the light need only make their normal phaser To-Hit Roll, with a bonus of +20 to chase off one parasite. Each 'shot' with the UV light takes 2 AP, and does not use up all remaining AP.

After the characters realize that the portable UV lights are too weak, any character with a Skill Rating of 20 or more in *Astronautics* or *Life Support Systems Technology* will know that the ship's lighting system may be programmed to emit high-intensity UV light. They will state that this may be accomplished in the engineering room on deck six.

If none of the players are familiar with the TV episode *Operation: Annihilate!*, the gamemaster will have to drop a clue here. Perhaps the luckiest character of the group might 'accidentally' bump into a scanner during a fight with the parasites. The machine could give off a burst of light that causes the attacking parasites to flee the area. The characters could then discover the parasites' weakness.

LET THERE BE LIGHT

Capturing the Engineering area will not be very easy, as there are 4 technicians and Chief Engineer Bahrrr there. Combat will result and should be judged using the section on **Combat With Infected Crewmembers**.

Once combat has been resolved, the character with the highest *Astronautics* or *Life Support Systems Technology* Skill Rating must make 3 successful Skill Rolls in a row in order to reprogram the lights. Each roll occupies 2 minutes of game time. If any roll is unsuccessful, all remaining rolls are made at a penalty of -5 to the Skill Rating; these penalties are cumulative.

When and if the character makes the third successful roll in a row, the parasites will make one last attack, in which 2 parasites will attack each player. These must be destroyed before the final connections are made and the switch is thrown, unless the player characters can keep the character doing the work from being attacked by a parasite for 4 full combat turns. If they can do this, the lights can be activated before the parasites all are dead.

THE AFTERMATH

If they can destroy this last wave, the interior of the *Republic* will be flooded with an eerie, purple light for 10 seconds. The flying parasites will drop to the floor, and burn up in a large puff of smoke. The crew of the *Republic* will be freed of the parasites infecting them, and they will return to normal.

When the player's ship returns to base, Awards Of Honor may be in order. No matter what the outcome, Science Officer Xepesna will be given a posthumous Medal Of Honor. If the characters were forced to destroy the *Republic*, those in the beam-over party will be granted Medals Of Honor as well, posthumously if necessary. If the characters managed to free the crew of the *Republic* from the parasite, the player characters will be granted the Star Fleet Citation For Conspicuous Gallantry, in addition to the Medal Of Honor. If, however, they allowed the *Republic* to return with the parasites intact, they may face a court martial when the crisis has been dealt with, depending on the level of their foolishness and their previous records. (The crisis will be dealt with, but many people will lose their lives in the process.)

Characters who make good use of their skills and abilities should be rewarded with chances to improve their ratings in this regard. A character who is especially active with fists or phaser in corridor battles should gain a few points (no more than 3) in the appropriate skill area. A 5-point rating increase in *Life Support Systems Technology* would be appropriate for the character who successfully reprograms the lighting system. Other appropriate, but moderate, skill increases are possible at the discretion of the gamemaster.

LIBRARY COMPUTER FILES

None of these files should be given to the players unless they call them up from a computer terminal aboard the *Republic* at some time during the adventure.

ASTROGATION DATA

Unless the characters brought over the astrogation data, these files are almost totally blank. The only information here are local star maps and navigation data gathered by the *Republic* since visiting the star BWCC98. If the characters did bring over the data, these banks are almost empty, but are rapidly being filled from the bridge science station. In either case, the earliest collected data will be on the BWCC98, and the Reference Stardate will be 2/0802.11.

PLANETARY DATA

There will be data on BWCC98-IV, giving the following information. The only class-M planet around BWCC98 is BWCC98-IV, a desert world about 11,000 km in diameter with a normal atmosphere. Its gravity is .95 G, and it has no satellites. No native life forms are listed. If the players check, the Reference Stardate listed for the discovery is 2/0802.10.

CAPTAIN'S LOG

Early entries all are rather normal and regular until those of the time when the astrogation data was lost. Many of the earlier entries contain personal notes. The entries dealing with the loss of the astrogation data are given below.

All later entries occur only when another planet is reached. They are sparse and very businesslike, containing no personal notes.

CAPTAIN'S LOG, STARDATE 6394.55 (Reference Stardate 2/0802.11)

Richard Masterson recording. We are in orbit around BWCC98-IV. It is a class-M planet, but very desert-like. Very little life registers on sensors, but there does seem to be evidence of a starship crashing on its surface. A landing party consisting of myself, Assistant Science Officer Rodriguez, Doctor T'Narra, Chief Engineer Bahrrr, and two technicians of Rodriguez's choosing will beam down to investigate.

Personal note: Other than the crash, this planet doesn't look nearly as interesting as some of the planets we've checked out thus far. When we finish here, I look forward to checking out several more-interesting things on this side of the Rift. The crash site looks like it may be several hundred years old, and what's left of the design doesn't look like anything we've ever encountered. We'll see if we can find out anything else from down there.

CAPTAIN'S LOG, STARDATE 6394.72 (Reference Stardate 2/0802.11)

Richard Masterson recording. The wrecked starship appears to be six hundred years old or so, with no sign of survivors. It seems to have been built by an alien race not yet encountered. Assistant Science Officer Rodriguez, Doctor T'Narra, and the technicians are gathering samples to send up before we leave. We have explored enough in the Rift area, and will be heading back to the Federation with our data as soon as they finish.

CAPTAIN'S LOG, STARDATE 6394.74 (Reference Stardate 2/0802.11)

Richard Masterson recording. Some micro-organism native to this planet has proved unhealthy to Edoans. Chief Science Officer Xepesna was receiving the first set of samples from the team below, when she went berserk and ran from the Transporter room. She locked herself in the central computer core, and proceeded to destroy the astrogation memory. Before we could break in and restrain her, she destroyed herself with a phaser. As her record has been spotless up to this date, I regard this as an unpreventable insanity. Let the record show that she could not have been in control of her actions at the time of her death.

CAPTAIN'S LOG, STARDATE 6394.75

Richard Masterson recording. All astrogation data is gone, and we now discover that Xepesna must have gone to the map room first, as all hard copies and data recordings of the data have been destroyed by phaser. We are stranded on this side of the Rift, with nothing to guide us home. The only safe course is to proceed from star to star and build up our data from nothing. Because the Rift extends for several hundred light years in both directions, I fear that we shall not be able to return to the Federation in our lifetimes without some outside help. We will begin broadcasting a repeating SOS, and resume our primary task of mapping this area of the Styx Rift.

SCIENCE OFFICER'S LOG

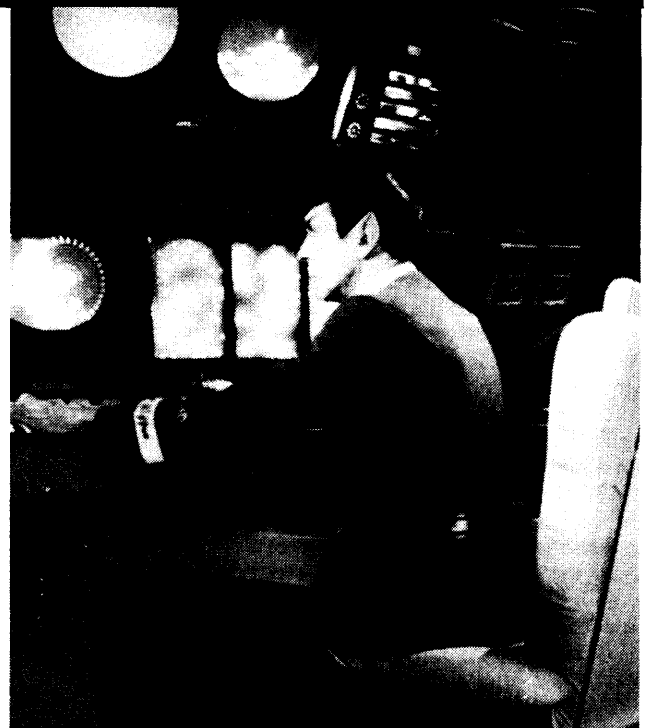

The recordings here are very regular and precise, until the entry for Stardate 6394.72. This entry is reproduced below. The gap shown in the print-out is actually where specific data has been erased crudely. When reading the entry to players, do not drop the voice at the gap. Merely begin the new sentence without ever indicating that the old was finished. If it is not clear through play that the character

notices the gap, have him make a Skill Roll against his rating in *Computer Operation*. A successful roll indicates that he notices the unusual gap.

The log entry after that listed below was made two days later by Assistant Science Officer Rodriguez. Other than a note about Xepesna's death and her own appointment to the position of Chief Science Officer by Capt. Masterson, there are no other references to the incident. From this point on, all entries are sparse and businesslike.

SCIENCE OFFICER'S LOG, STARDATE 6594.72

Science Officer Xepesna recording. The landing party is beaming up the first set of samples from the planet's surface. Samples include the following: Soil sample, 1 each. Air sample, 1 each. Plant samples,

Preparing to receive samples from the alien ship.



LIFE FORMS FILE

The following entry is only one of the listings in the file for life-forms of its physical description. It may not come to light unless the key-words "mind-control," "parasite," "Enterprise," or "Deneva" are used in the search. If it is not apparent through play that this file will be found, then require the searching player to make a Skill Roll against his character's rating in *Computer Operation*, averaged with the rating in *Exobiology*. If the appropriate key-words are used, and there is plenty of time to allow the computer to search, then the response is automatic; if time is not available, a standard Skill Roll against the rating in *Computer Operation* should be required.

FLYING PARASITES

First encountered by the *USS Enterprise* on Deneva, a life-form has been discovered that is described as a flying parasite. It is a flat, levitating single-celled creature that, in

large aggregation, make up a huge single nervous system of considerable power. The individual cells are part energy and part matter, and are somewhat resistant to both physical attack and phaser disintegrate.

These cells attach themselves to living organisms, controlling their actions through the infliction of severe pain that, left unchecked, can produce insanity and death. The parasite multi-organism encountered by *Enterprise* destroyed the civilizations of Beta Portalan, Lavinius V, Theta Cygni XII, and Ingraham B before forcing the inhabitants of the last-named world to build spacecraft to convey them to Deneva.

In experimentation on Science Officer Spock, a Vulcan who was a victim of one of the parasites, it was determined by *Enterprise* Chief Surgeon Leonard McCoy that the organisms could not stand high-intensity ultraviolet light. Use of ultraviolet-producing flare satellites allowed *Enterprise* Captain James T. Kirk to exterminate the parasites on Deneva. Later UFP expeditions traced the organism's path and destroyed all traces on the other infected planets.

Other groups of these organisms may exist. For this reason, a standing Star Fleet directive exists that makes containment or destruction of such organisms a top-priority objective.

PERSONNEL RECORDS

The records for the personnel of the *Republic* will be those given in the section **Cast Of Characters**. Only the references to Chief Science Officer Xepesna will be the least bit odd. Her personnel file gives a reference noting that she was a five-time Federation-wide chess champion, but her Skill Rating in *Gaming* is listed as 05. If it is not apparent through play that this is strange, the gamemaster should require the searching character(s) to make a secret Saving Roll against INT with a penalty of -30. If the information is conveyed to all players about Xepesna's championship, any player with a *Gaming* specialty in Chess has a chance to remember that there has never been anyone who has won the Federation-wide championships 5 times, and that most of the players who have won it even once have been Vulcans. Require a Skill Roll against the rating in *Gaming*, with a bonus of +30 added to the rating.

RECREATIONAL TAPES

This file has been largely wiped out of the computer's memory. All of the normal recreational programs are gone, including fiction reading material, computer games, and recreational video programs, with one exception. The menu indicates that the chess-playing program is still intact.

Any person who tries to play chess with the computer or accesses the chess-playing program will find, not a game of chess but Xepesna's final personal log. The message, voice but no video, follows; the voice is panicky and strained, and the message ends as if more were intended, but never finished.

PERSONAL LOG

Science Officer Xepesna recording. I am the only one left. The rest have all been taken over! If they catch me, I am sure they will kill me. My only recourse is to prevent them from returning to the Federation with this menace. I have destroyed the contents of the map room, and now I must destroy all astrogation data. I've left a clue to this note, and pray it is found. To anyone hearing this, I have but one message ... beware the flying creatures and keep this ship away from the rest of the galaxy. Destroy them if you must, but ... no! They're out there ... They'll get me too! ...

CAST OF CHARACTERS

THE COMMAND PERSONNEL

Name: MASTERSON, Richard V.
Rank: Captain
Current Assignment: Galaxy Exploration Command,
USS Republic, NCC - 1373

Position: Captain
Race: Human
Sex: Male
Age: 45
Attributes:

STR - 63	CHA - 54
END - 65	LUC - 60
INT - 71	PSI - 62
DEX - 62	

Combat Statistics:
To-Hit; Modern: 58 **Bare-hand Damage:** 1D10 + 3
HTH: 57 **AP:** 10

Significant Skills:

Communications Systems Operation	56
Language, Klingonaase	28
Leadership	59
Negotiation/Diplomacy	29
Starship Combat Strategy/Tactics	75

Name: JANOVIK, Talia
Rank: Commander
Current Assignment: Galaxy Exploration Command,
USS Republic, NCC - 1373
Position: First Officer, Chief Navigator

Race: Human
Sex: Female
Age: 32
Attributes:

STR - 51	CHA - 53
END - 59	LUC - 49
INT - 71	PSI - 51
DEX - 53	

Combat Statistics:
To-Hit; Modern: 62 **Bare-hand Damage:** 1D10 + 3
HTH: 44 **AP:** 9

Significant Skills:

Computer Operation	50
Deflector Shield Operation	40
Deflector Shield Technology	22
Language, Russian	47
Negotiation/Diplomacy	20
Space Sciences	
Astrogation	59
Astronomy	54
Astrophysics	57
Starship Helm Operation	20
Starship Sensors	30
Starship Weaponry Operation	14

Name: DAX, Chal'n
Rank: Lieutenant
Current Assignment: Galaxy Exploration Command,
USS Republic, NCC - 1373

Position: Chief Helmsman
Race: Andorian
Sex: Male
Age: 36
Attributes:

STR - 64	CHA - 55
END - 59	LUC - 34
INT - 61	PSI - 05
DEX - 55	

Combat Statistics:
To-Hit; Modern: 54 **Bare-hand Damage:** 1D10 + 3
HTH: 43 **AP:** 9

Significant Skills:

Communications Systems Operation	10
Computer Operation	71
Space Sciences	
Astrogation	20
Astronomy	26
Astrophysics	23
Starship Combat Strategy/Tactics	40
Starship Helm Operation	47
Starship Sensors	20
Starship Weaponry Operation	50

Name: T'NARRA
Rank: Lt. Commander
Current Assignment: Galaxy Exploration Command,
USS Republic, NCC - 1373
Position: Chief Medical Officer

Race: Vulcan
Sex: Female
Age: 43
Attributes:

STR - 76	CHA - 60
END - 65	LUC - 01
INT - 73	PSI - 71
DEX - 64	

Combat Statistics:
To-Hit; Modern: 42 **Bare-hand Damage:** 2D10 + 6
HTH: 63 **AP:** 10

Significant Skills:

Computer Operation	39
Environmental Suit Operation	19
Life Sciences	
Bionics	51
Botany	19
Genetics	32
Zoology	25
Life Support Systems Technology	10
Medical Sciences	
General Medicine, Vulcan	82
Human	74
Surgery	51
Pathology	48
Psychology, Vulcan	30
Starship Sensors	20

Name: XEPESNA
Rank: Lt. Commander
Current Assignment: Galaxy Exploration Command,
USS Republic, NCC - 1373

Position: Chief Science Officer

Race: Edoan
Sex: Female
Age: 46

Attributes:

STR - 55 CHA - 60
 END - 53 LUC - 49
 INT - 71 PSI - 01
 DEX - 66

Combat Statistics:

To-Hit; Modern: 49 Bare-hand Damage: 1D10 + 3
 HTH: 51 AP: 10

Significant Skills:

Computer Operation 95
 Computer Technology 24
 Electronics Technology 28
 Gaming, Chess 05
 Physical Sciences
 Chemistry 45
 Mathematics 79
 Physics 45
 Space Sciences
 Astronomy 35
 Astrophysics 27
 Starship Sensors 64
 Transporter Operational Procedures 25

Gamemasters Note:

This character will be listed in Republic's files as deceased; this will not be so noted in the files on the characters' own ship. There will also be a note that says the character is five-times Federation-wide chess champion on the Republic's file only.

Name: BAHRRR
Rank: Lt. Commander
Current Assignment: Galaxy Exploration Command,
USS Republic, NCC - 1373

Position: Chief Engineer

Race: Tellarite
Sex: Male
Age: 44

Attributes:

STR - 60 CHA - 57
 END - 67 LUC - 41
 INT - 81 PSI - 02
 DEX - 56

Combat Statistics:

To-Hit; Modern: 57 Bare-hand Damage: 1D10 + 3
 HTH: 51 AP: 9

Significant Skills:

Computer Operation 40
 Computer Technology 32
 Damage Control Technology 39
 Deflector Shield Technology 10
 Electronics Technology 33
 Life Support Systems Technology 20
 Physical Sciences
 Mathematics 47
 Physics 10
 Space Sciences
 Astronautics 60
 Starship Weaponry Technology 30
 Transporter Operational Procedures 20
 Transporter Systems Technology 34
 Warp Drive Technology 57

Name: R'RANDRR
Rank: Lieutenant
Current Assignment: Galaxy Exploration Command,
USS Republic, NCC - 1373

Position: Chief Communications Officer

Race: Caitian
Sex: Male
Age: 34

Attributes:

STR - 60 CHA - 65
 END - 66 LUC - 46
 INT - 81 PSI - 68
 DEX - 71

Combat Statistics:

To-Hit; Modern: 61 Bare-hand Damage: 1D10 + 3
 HTH: 58 AP: 11

Significant Skills:

Communications Systems Operation 61
 Communications Systems Technology 36
 Computer Operation 52
 Damage Control Technology 78
 Electronics Technology 10
 Language
 Klingonaase 72
 Romulan 43
 Negotiation/Diplomacy 20
 Starship Sensors 10
 Transporter Operational Procedures 34

Name: RODRIGUEZ, Samuel
Rank: Lt. Commander
Current Assignment: Galaxy Exploration Command,
USS Republic, NCC - 1373

Position: Chief Security Officer

Race: Human
Sex: Male
Age: 36

Attributes:

STR - 81 CHA - 54
 END - 62 LUC - 45
 INT - 61 PSI - 25
 DEX - 53

Combat Statistics:

To-Hit; Modern: 61 Bare-hand Damage: 2D10
 HTH: 55 AP: 9

Archaic Pistols: 44
 Knife: 46

Significant Skills:

Administration 44
 Computer Operation 40
 Language, Tellarite 20
 Leadership 40
 Marksmanship, Archaic Pistols 32
 Medical Sciences
 Psychology, Human 15
 Negotiation/Diplomacy 20
 Personal Combat, Knife 38
 Personal Weapons Technology 20
 Planetary Survival 15
 Security Procedures 30
 Small Unit Tactics 23
 Starship Combat Strategy/Tactics 20
 Zero-G Operations 24

Gamemasters Note:

This character is listed as the husband of Assistant Science Officer Juliet Rodriguez. The fact that they seem to have no special feeling for each other may be a clue for the players, though if questioned they will confirm their relationship.

Name: RODRIGUEZ, Juliet

Rank: Lieutenant

Current Assignment: Galaxy Exploration Command,
USS Republic, NCC - 1373

Position: Asst. Science Officer

Race: Human

Sex: Female

Age: 28

Attributes:

STR - 69	CHA - 61
END - 64	LUC - 91
INT - 76	PSI - 01
DEX - 65	

Combat Statistics:

To-Hit; Modern: 52	Bare-hand Damage: 1D10 + 3
HTH: 50	AP: 10

Significant Skills:

Computer Operation	33
Damage Control Technology	25
Environmental Suit Operation	10
Life Sciences	
Botany	39
Ecology	20
Exobiology	52
Genetics	38
Zoology	32
Medical Sciences	
General Medicine, Human	17
Physical Sciences	
Chemistry	20
Mathematics	46
Physics	30
Planetary Sciences	
Geology	17
Hydrology	19
Meteorology	12
Starship Sensors	53
Transporter Operational Procedures	26

Gamemasters Note:

This character is listed as the wife of Chief Security Officer Samuel Rodriguez. The fact that they seem not to have any special feeling for each other may be a clue to the players, though if questioned they will confirm the relationship. In the Republic's records only, this character is now listed as Chief Science Officer.

THE EXTRAS

When the gamemaster needs an encounter or combat situation other than with one of the above characters, the following guidelines may be used, and the gamemaster may alter them to suit the situation.

Security Guard

Attributes:

STR - 70	END - 70	INT - 50
DEX - 70	CHA - 45	

Combat Statistics:

To-Hit; Modern: 55
HTH: 55

Other Crewman

Attributes:

STR - 55	END - 55	INT - 60
DEX - 60	CHA - 55	

Combat Statistics:

To-Hit, Modern: 40
HTH: 40

Engineering Technician

Attributes:

STR - 60	END - 55	INT - 60
DEX - 60	CHA - 55	

Combat Statistics:

To-Hit; Modern: 35
HTH: 50

GAMEMASTER NOTES

BACKGROUND INFORMATION

THE PARASITES

Please remember that these parasites, though similar, are a different strain than the Deneva plague. They do not remain attached to their 'hosts,' but inject a quantity of material that makes the host, like the flyer, a part of the mass intelligence.

be kept in below-decks cold storage facilities. The ones found in the sick bay lab, which have been brought up to infect the newcomers, are still a little sluggish from long inactivity.

INFECTING THE *REPUBLIC*

The crashed alien spaceship mentioned in the Captain's log brought this particular group to the planet where the *Republic* found them. The parasites infected the planet's animal life, and then the *Republic's* landing party.

Upon beaming back, the infected landing party released flying parasites to infect the rest of the *Republic's* crew. Only Science Officer Xepesna, the only Edoan aboard, escaped.

ALIEN CREATURE RECORD

Name: Flying Parasite

Life Form: Special Size: Small Feeding Habits: Parasitic

Attributes:

STR 30 END 30 DEX 115 MENT reactant as individuals

(For Intellegent Races Only)

INT 65 as CHA _____ LUC _____ PSI _____
mass-mind

Tactical Movement and Combat Statistics:

AP 18 Combat Skill Rating 0 Damage 1 pt. + special Armor special

General Description: These creatures are flat disks, 25 cm in diameter. They are capable of flight. They are unaffected by energy weapons, except phaser on disrupt setting. This does 40 points stun damage. Physical attacks do half damage, as stun damage. High-intensity ultraviolet light destroys the creature. A successful attack will allow the creature to inject parasitic material into the victim, bringing the host under the control of the creature's mass-mind.

These creatures are flat, measuring about 25 cm in diameter. Each looks like a huge cell. They are half physical and half energy; thus, they are very difficult to damage.

The flying parasites encountered in this adventure are mutated from those seen in the TV episode *Operation: Annihilate!* They inject parasitic material into another creature, which becomes the host. The original parasite then becomes torpid and lethargic until it can manufacture more injectable parasitic material. The host comes under the control of the injected parasite; it acts in the interests of the flying parasites, gathering up torpid flyers that have injected their material and protecting them.

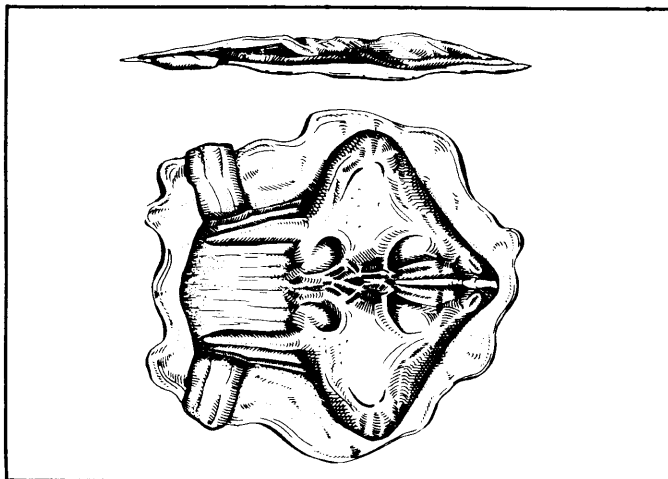

The flying forms are only semi-intelligent alone, but they form a huge supercolony that has a collective intelligence. The flyers, immune to the temperature extremes and airlessness of space, prefer cold temperatures, so they mostly will

Something in Edoan body chemistry rejects the parasitic implant. Xepesna escaped capture long enough to destroy all navigational data the *Republic* had. In the stellar Rift, with few nearby stars on which to take a navigational fix, the *Republic* had little chance of finding the way back to the Federation to infect others. Xepesna eventually was caught and killed by her parasite-controlled associates, but not before wiping all recreation tapes except the chess files and planting the chess references in her own files as a clue.

The parasite-controlled *Republic* crew doctored all computer records to prevent anyone who might come aboard from discovering the truth about Xepesna's death. This included the clumsy removal of any reference to animal life on the planet where the parasites were encountered, leaving a tell-tale blank spot. The crew did not notice the missing recreation files, because they have no particular interest in recreation. They also missed the subtle references to chess added to all Xepesna's personnel and medical files, and her last log entry remained in the computer, hidden and waiting for someone to find it.

HINTS ON PLAY

The gamemaster should prepare to be flexible with this adventure. The players wander around at first, chasing incorrect ideas. If so, let them for a while, but be sure to get at least one or two down to the Sick Bay to be attacked by parasites before they grow bored. It is important to provide signposts without directing the play, because the players should not be left long to wonder what the adventure is.

After the combat at Sick Bay, let any survivors spread the word among the others and warn their ship. After that, let the players take whatever action seems best to them.

This adventure has the potential for killing several player characters, particularly if none of the players aboard the *Republic* get the idea to use ultraviolet light against the creatures. If this seems too dangerous, provide a signpost so that the players at least have access to the idea, whether or not they follow it up. Of course, if the players aboard the *Republic* are all captured, they will be infected by the parasites.

If all aboard the *Republic* die or are infected, the player characters' ship will be forced to destroy the *Republic* to insure that it cannot get back to the Federation and spread the parasites. This may require the sacrifice of the player characters aboard *Republic*, because the parasite-possessed crew will not give up until they are killed, the parasites within them are destroyed by high-intensity ultraviolet light, or the *Republic* is destroyed.

COMBAT WITH THE PARASITES

Damage From The Parasites

A parasite that makes a successful To-Hit Roll will attach itself to the character hit, who may take all actions remaining in the combat turn. Give the player a chance to make a Saving Roll against his character's LUC score. If the roll is successful, the character takes one point of wound damage as the parasite tries to grip him, but he escapes being injected.

If the roll is not successful, the parasite causes one point of wound damage immediately as it attaches itself to the character's body. Thousands of tiny tentacles stiffen and hook into the flesh, through clothing and even through a normal environmental suit. This is quite painful.

Once attached, the parasite will hang on despite all physical attempts to remove it. After 3 combat rounds, the parasite will be attached securely enough to permit infection. During this period, the victim will be in extreme pain, unable to do anything but writhe and scream.

If the victim can be immobilized during this period, the parasite CAN be removed if it is stunned (see the section on **Damaging The Parasites**) and the character will be safe. If this is done, no To-Hit Roll will be necessary.

After the 3 turns have passed, the parasite inserts a needle-sharp probe into the victim and injects the infecting substance. The infection will take hold immediately, and the character's actions will be controlled by the parasite mass-mind. The parasite then falls off; it becomes inactive and cannot infect another player for a time greater than the likely duration of the combat.

Effects Of Infection

Once infected, a player character no longer will be in control of his own actions. He will fall to the ground, lying there helpless for one full combat turn. At the beginning of the next turn, the parasite is in control and the gamemaster will take control of the character. The player may still move the character and make Saving Rolls to keep the player involved with the action, but he must follow the gamemaster's directions any time the parasite would be directing the character's actions.

Edoans are immune to the parasites. They may be attacked like other player characters, and a successful attack will do one point of damage. The parasite will fall off and become inert as above.

Vulcans might be able to control their own actions, for a time, despite the parasite by the use of Vulcan mental disciplines. It will take time for the player character to assert such control, however. If such a player can be restrained for 6 combat turns, an infected Vulcan character may ONLY ONCE attempt a Saving Roll against his INT score.

If the roll is successful, the Vulcan's mental discipline allows him to control his own actions for a time. The length of time is indeterminate to players. It obviously will not last

forever, for the Vulcan crewmembers of the *Reliant* eventually were overcome. The gamemaster may wish to require the player to make additional Saving Rolls at one crisis point in the adventure (perhaps when the player characters are working on the lighting system). If the roll is not successful, the parasite takes control after one turn, during which the Vulcan feels the protection of his mental discipline fading. An infected Vulcan cannot be reinfected, though parasites may try, but he cannot attempt any psionic feats.

Damaging The Parasites

In combat, the parasites are hard to damage because they are partly physical and partly energy. They do not exhibit much intelligence when attacking. When this is played out, all of their actions should be random.

The only phaser setting that affects them is *disrupt*, which does 40 points of stun damage; any parasite stunned in this fashion will remain stunned for 1D10 turns. Physical attacks do only half normal damage, and only do stunning damage in any case. The only way to kill them is with ultraviolet radiation (black-light).

Although the flying parasites are invulnerable to all but phaser disrupt settings, an infected crewman is not. Phaser stun and sedatives will keep the body helpless, even though they will not remove the parasite.

PLAYING INFECTED CREWMEMBERS

Once a person is infected, the injected parasite form has access to all that person's memories and skills, but the infected person does not have much imagination or foresight. They tend to be a bit more slow-witted than an uninfected person. This explains the crudeness of the altering of records and the holes in the cover story used to get the navigational data from the players. The gamemaster should play infected characters accordingly, as normally-skilled individuals who are, for some reason, not as quick on the uptake as most Star Fleet officers.

Combat With Infected Hosts

Crewmen fighting the escaping players will also fight with a lack of tactical brilliance (including disdaining the use of phasers for the most part). If the characters seem to be getting off too easy, let the attackers get the idea and start digging out phasers from the weapons lockers. The infected crewmen will use phasers set on stun only.

Freeing Infected Hosts

Infected characters or crewmen may not be freed from the parasite except by the use of intense UV light.

THE STARSHIP COMBAT

The *Republic* will get one free salvo at the player characters' unshielded ship. This shot should be considered an automatic hit, using whatever starship combat system that has been adopted. This free shot may or may not handicap the player characters' ship, depending mostly on luck.

During the battle between the two starships, if such occurs, the *Republic* should not use complex tactics, preferring to just move and shoot.

FOLLOW-UP ADVENTURES

If the *Republic* somehow manages to escape, it may spark another encounter and a second attempt at stopping the spread of the parasites.

A follow-up adventure could occur at the planet where the parasites were found by the *Republic*. The parasites there must be killed, perhaps by the same ultraviolet-producing satellite flares used by *USS Enterprise* to kill the parasites on Deneva.

Information decoded from the crashed spaceship's logs might lead to the tracing of the infection to other planets, setting off a whole series of adventures.

WEAPONS TABLE

WEAPON TYPE	PARRY	DAMAGE	POINT					AMMO/		OVERLOAD	
			BLANK	SHORT	MEDIUM	LONG	EXTREME	POWER	GRAZE		DRAIN
<i>Range Modifier</i>			+ 15	+ 0	- 15	- 30	- 45				
PHASER I-A	-		1	2-5	6-12	13-30	31-50	20			30 squares
stun		75*							25*	1	
wide angle stun		75*	1	(2-5)					25*	4	
heavy stun		120*							40*	2	
heat		40							20	1	
disrupt		150							50	2	
disintegrate		DESTROYED							50	4	
PHASER II-A	-		1	2-10	11-24	25-60	61-100	35			100 squares
stun		75*							25*	1	
wide angle stun		75*	1	2-10					25*	4	
heavy stun		120*							40*	2	
heat		40							20	1	
disrupt		150							50	2	
disintegrate		DESTROYED							50	4	
PHASER RIFLE-A	-		1	2-15	16-35	36-90	91-150	50			125 squares
stun		75*							25*	1	
wide angle stun		75*	1	(2-15)					25*	4	
heavy stun		120*							40*	2	
heat		40							20*	1	
disrupt		150							50	2	
disintegrate		DESTROYED							50	4	
PHASER I-B	-		1	2-6	7-15	16-30	31-60	20			30 squares
stun		80*							30*	1	
wide angle stun		80*	1	(2-6)					30*	4	
heavy stun		130*							50*	2	
heat		40							20	1	
disrupt		160							60	2	
disintegrate		DESTROYED							60	4	
PHASER II-B	-		1	2-12	13-30	31-60	61-100	40			110 squares
stun		80*							30*	1	
wide angle stun		80*	1	(2-15)					30*	4	
heavy stun		130*							50*	2	
heat		40							20	1	
disrupt		160							60	2	
disintegrate		DESTROYED							60	4	
MARK I HAND DISRUPTOR	-	75	1	2-4	5-10	11-20	21-35	20	25	2	
MARK I DISRUPTOR RIFLE	P	75	1	2-10	11-25	26-40	41-100	50	25	2	
MARK II HAND DISRUPTOR	-							20			
standard shot		75	1	2-4	5-10	11-25	26-45		25	2	
high-power shot		DESTROYED	1	2-4	5-10	11-25	NONE		50	6	
MARK III HAND DISRUPTOR	-							25			
standard shot		75	1	2-5	6-15	16-35	36-50		25	2	
high-power shot		DESTROYED	1	2-5	6-15	16-35	NONE		50	6	
MARK III DISRUPTOR	P							65			
standard shot		75	1	2-10	11-20	21-60	61-90		25	2	
high-power shot		DESTROYED	1	2-10	11-20	21-60	NONE		50	8	
HAND LASER (old-style)	-	80	1	2-6	7-15	16-30	31-60	20	20	1	
LASER RIFLE (old-style)	-	80	1	2-15	16-40	41-100	101-200	40	20	1	
POLICE STUNNER	-	75*	1	2-5	6-12	13-30	31-50	20	25*	1	
STUNCLUB	P	40*	---	---	---	---	---	---	---	---	
GORNBLASTER, MARK I	-	50	1	2-4	5-8	9-20	21-40	25	20	1	
GORNBLASTER, MARK II	-	80	1	2-5	6-9	10-25	26-50	25	30	1	
GORN SONIC STUNNER	-	150*	1	2-5	6-12	13-30	31-50	30	20*	2	

*Non-permanent damage

Phaser I, II and rifle stun effects last 2D10 + 10 minutes.
Heavy stun effects last 3D10 + 20 minutes.

ATTRIBUTES

INITIAL ROLL
 Dice Roll: As Below
 Modifiers: As Below

INITIAL DICE ROLLS

Attribute	Roll
STR	40 + 3D10
END	40 + 3D10
INT	40 + 3D10
DEX	40 + 3D10
CHA	40 + 3D10
LUC	D100
PSI	D100

RACIAL MODIFIERS TO ATTRIBUTES

	STR	END	INT	DEX	CHA	LUC	PSI
Human							30
Andorian	+10	+5					20
Caitian		-5		+20	+5		-30
Edoan	-5		+15				-35
Tallante	+5	+5				-10	-20
Vulcan	+20	+10	+10				-40

PLAYER CHARACTER RACES

BONUS POINTS
 Dice Roll: D100/2, Round Down
 Choice: Any But PSI
 Restrictions:
 No More Than 30 in One Attribute
 No Attribute More Than 100

PRE-ACADEMY SKILLS

Number: INT/10, Round Down
 Rating: 1D10
 Choice: Half From Each Table

PRE-ACADEMY SKILLS TABLE

For Educational Background:

- Computer Operation
- Language
- Life Sciences
- General Medicine (First Aid only)
- Physical Sciences
- Planetary Sciences
- Social Sciences
- Space Sciences
- Trivia

For Personal Development:

- Artistic Expression
- Carousing
- Communication Systems Operation
- Communication Systems Technology
- Computer Technology
- Electronics Technology
- Gaming
- Language
- Leadership
- Marksmanship, Archaic Weapon
- Mechanical Engineering
- Negotiation/Diplomacy
- Personal Combat, Armed
- Personal Combat, Unarmed
- Planetary Survival
- Sports
- Streetwise
- Trivia
- Vehicle Operation

CADET CRUISE RESULTS

ASSIGNMENT
 Dice Roll: D100
 Modifiers: As Below

CADET CRUISE ASSIGNMENT TABLE

Die Roll	Assignment
15 or less	Exploration Command, Const. class
16-25	Galaxy Exploration Command
26-50	Military Operations Command
51-75	Colonial Operations Command
76+	Merchant Marine Command

Modifiers For Cadet Cruise Assignment

For Attribute Scores

INT 70+	-10
INT 60-69	-5
LUC 70+	-10
LUC 60-69	-5
LUC 40 or less	+5
Per Previous Cadet Cruise	+10

DEPARTMENT HEAD SCHOOL SKILLS

CURRICULUM SKILLS
 Number: 3
 Rating: As Below
 Choice: As Below

DEPARTMENT HEAD SCHOOL SKILLS TABLE

Administration	40
Computer Operation	15
Leadership	20

ADVANCED TRAINING
 Number: INT/10, Round Down
 Rating: 1D10
 Choice: Only Skills Already Known

RANK
 Automatic 1-Rank Promotion

ACADEMY SKILLS

CURRICULUM SKILLS
 Number: As Below
 Rating: As Below
 Choice: As Below

ACADEMY CURRICULUM SKILLS TABLE

For Core Curriculum:

- Computer Operation 20
- Language One at 10
- Life Sciences One at 10
- Physical Sciences One at 10
- Planetary Sciences One at 10
- Social Sciences
- Federation Culture/History 15
- Federation Law 15

For Space Science Curriculum:

- Astronomy 10
- Other Space Sciences Two at 10
- Damage Control Procedures 10
- Environmental Suit Operation 10
- Starship Sensors 10
- Transporter Operation Procedures 10
- Zero-G Operations 10

For Officer Training Curriculum:

- General Medicine (First Aid) 10
- Instruction 10
- Leadership 10
- Marksmanship, Modern Weapon 20
- Personal Combat, Unarmed 20
- Personal Weapons Technology 5
- Small Equip. Syst. Operation 10

ACADEMY SKILLS

OUTSIDE ELECTIVES
 Number: 5
 Rating: 10
 Choice: As Below

ACADEMY ELECTIVE SKILLS TABLE

- Artistic Expression
- Carousing
- Gaming
- Marksmanship, Archaic Weapon
- Negotiation/Diplomacy
- Personal Combat, Armed
- Shuttlecraft Pilot
- Sports
- Streetwise
- Trivia

ADVANCED STUDY
 Number: INT/10, Round Down, +5
 Rating: 1D10
 Choice: Only Skills Already Known

RESULTS

Dice Roll: D100
 Modifiers: As Below

CADET CRUISE RESULTS TABLE

Die Roll	Result
5 or less	Passed with High Honors
6-15	Promoted to Lieutenant, jg
16-15	Passed with Honors
16-60	Assigned as Ensign
60+	Passed, assigned as Ensign
60+	Repeat Cruise Procedure

Modifiers To Cadet Cruise Results

For Assignment:

Exploration Command, Const. class	-20
Exploration Command	-10
Military Operations Command	-10
Colonial Operations Command	No Modifier
Merchant Marine Command	+10

For Attribute Scores

LUC 70+	-10
LUC 60-69	-5
LUC 40 or less	+5
For Any Previous Cruise	+10

COMMAND SCHOOL SKILLS

CURRICULUM SKILLS
 Number: 5
 Rating: As Below
 Choice: As Below

COMMAND SCHOOL SKILLS TABLE

Leadership	10
Negotiation/Diplomacy	10
Social Science	
Federation Culture/History	5
Federation Law	10
Starship Combat Strategy/Tactics	40

ADVANCED TRAINING
 Number: INT/10, Round Down
 Rating: 1D10
 Choice: Only Skills Already Known

RANK
 Automatic 1-Rank Promotion

BRANCH SCHOOL SKILLS

CURRICULUM SKILLS
 Number: As Below
 Rating: As Below
 Choice: All From One School

COMMUNICATIONS/DAMAGE CONTROL BRANCH SCHOOL CURRICULUM TABLE

Communication Systems Operation	40
Communication Systems Technology	10
Computer Technology	10
Damage Control Procedures	30
Language	30 total, used in any way 30 total, used in any way
Racial Culture/History	30 total, used in any way

ENGINEERING BRANCH SCHOOL CURRICULUM TABLE

Astronautics (Space Science)	10
Communication Systems Technology	10
Computer Technology	10
Deflector Shields Technology	10
Electronics Technology	10
Life Support Systems Technology	10
Mechanical Engineering	10
Personal Weapons Technology	5
Starship Weapons Technology	10
Shuttlecraft Systems Technology	10
Small Equip. Syst. Technology	10
Transporter Systems Technology	10
Warp Drive Technology	10
Specialties (from above skills)	three at 30 extra one at 10 extra one at 5 extra

HELM BRANCH SCHOOL CURRICULUM TABLE

Shuttlecraft Pilot	10
Space Sciences	
Astrigation	10
One other	10
Starship Combat Strategy/Tactics	10
Starship Helm Operation	40
Starship Sensors	40
Starship Weapons Operation	40
Starship Weapons Technology	10
Warp Drive Technology	10

OUTSIDE ELECTIVES
 Number: 2
 Rating: 1D10
 Choice: Open

ADVANCED TRAINING
 Number: 5
 Rating: 1D10
 Choice: Only Skills Already Known

BRANCH SCHOOL SKILLS

MEDICAL BRANCH SCHOOL CURRICULUM TABLE

Computer Operation	20
Language	20
Life Sciences	three at 10
Life Support System Technology	10
Medical Sciences	
General Medicine	60
Specialty Race	total of 40
Other Races	
Psychology	40
Specialty Race	total of 40
Other Races	total of 50
Other Specialties	
Small Equipment Systems Operation	10

NAVIGATION BRANCH SCHOOL CURRICULUM TABLE

Computer Operation	20
Deflector Shield Operation	40
Deflector Shield Technology	10
Space Sciences	
Astrigation	40
Others	two at 10
Starship Sensors	10

SCIENCE BRANCH SCHOOL CURRICULUM TABLE

Computer Operation	30
Computer Technology	10
Electronics Technology	10
Environmental/Suit Operation	20
Language	20
Sciences (any except Medical or Social)	
Related majors	two at 40
Minors	two at 30
Other fields	four at 10
Any field	total of 20
Starship Sensors	30

SECURITY BRANCH SCHOOL CURRICULUM TABLE

Environmental/Suit Operation	10
Federation Law (Social Science)	5
Marksmanship, Modern Weapon	20
Personal Combat, Unarmed	20
Personal Weapons Technology	5
Psychology, Native (Medical Science)	10
Security Procedures	40
Small Unit Tactics	20
Shuttlecraft Pilot	20

POST ACADEMY EXPERIENCE AND SKILLS

NUMBER OF TOURS SERVED
 Dice Roll: 1D10/2, Round Down
 (if result is 0, make it 1)
 Modifiers: As Below

TABLE OF MODIFIERS FOR TOURS SERVED

For Attributes:

INT 60+	-1 tour
LUC 60+	-1 tour
LUC 40 or less	+1 tour

For Destined Rank:

Ensign	-1 tour
Lieutenant, jg, or Lieutenant	No Modifier
Lieutenant Commander or Commander	+1 tour
Captain	-2 tours
Commodore or above	+3 tours

For Destined Position:

Captain or First Officer	-2 tours
Department Head	+1 tour
Const. class officer	+1 tour

POST ACADEMY EXPERIENCE AND SKILLS

FIRST TOUR ASSIGNMENT
 Dice Roll: D100
 Modifiers: As Below

FIRST TOUR ASSIGNMENT TABLE

Die Roll	Pasting
10 or less	Const. Class Starship
11-20	Galaxy Exploration Command
21-30	Military Operations Command
31-60	Colonial Operations Command
61 or more	Merchant Marine Command

Modifiers For Tour Assignments

For Attributes:

INT 70+	-10
INT 60-69	-5
LUC 70+	10
LUC 60-69	5

For Cadet Cruise Results

High Honors	20
Honors	10

OFFICER EFFICIENCY REPORTS

Dice Roll: D100
 Modifiers: As Below

OFFICER EFFICIENCY REPORT RESULTS TABLE

Die Roll	Report	Modifiers To OER Results
10 or less	Outstanding	INT 60+ -10
1-25	Excellent	LUC 70+ -10
26-75	As Expected	LUC 60-69 -5
76-90	Fair	
91 or more	Poor	

TOUR ASSIGNMENTS

Dice Roll: D100
 Modifiers To Determine Table: As Below
 (modifiers are not applied to roll)

TOUR ASSIGNMENTS TABLE

Assignment	25 or less	Die Roll Tables For Various Modifiers	5 to +5	+10 to +20	+25
Constitution-Class Starship	01-30	01-20	01-10
Galaxy Exploration Command	31-50	21-40	11-20	01-10	...
Military Operations Command	51-70	41-60	21-30	11-20	01-10
Colonial Operations Command	71-75	61-70	31-60	21-50	11-50
Merchant Marines Command	76-80	71-80	61-90	51-90	51-90
Star Base Headquarters Command	81-90	81-90	81-90	91-90	91-90
Star Fleet Academy	91-90	91-90	91-90

Modifiers For Tour Assignment Rolls

For Luck:

LUC 70+	-10
LUC 60-69	5
LUC 40 or less	+5

For Officer Efficiency Reports

Outstanding	20
Excellent	10
As Expected	0
Fair	+10
Poor	+20

SKILL ADVANCEMENT

Number: As Below
 Rating: 1D10
 Choice: Only Skills Already Known

SKILL ADVANCEMENT TABLE FOR POST-ACADEMY EXPERIENCE

For Service:

Per 2 years of service	1 roll
Per 2 years on Const.-class ship	1 extra roll
Per tour as Academy Instructor	1 extra roll in Instruction
Per tour on Star Base duty	1 extra roll in Administration
Per tour on Merchant Marine or Star Base duty	1 extra roll in Carousing or Streetwise

For Attributes:

INT 70+	2 rolls
INT 60-69	1 roll
LUC 70+	2 rolls
LUC 60-69	1 roll

For Cadet Cruise Results:

Per Cadet Cruise after first	1 extra roll in Carousing or Streetwise
------------------------------	---

CHARACTER AGE

Add years spent to age when entering Academy.

AGE FOR THE TRAINING PROCESS

Age when entering Academy 18

Modifiers For Training

Academy	4
Branch School	
Science	3.5
Medicine	3.5
Engineering	2.5
Others	1.5
Per Cadet Cruise	.5
Department Head School	1
Command School	1
Per year of service	1

The STAR TREK adventure continues . . .



Bring your *STAR TREK* role playing universe up to date with the official **Star Fleet Sourcebook Update**. It gives all the information necessary to play your games at the time of the movies.

This supplement contains a complete time line from the beginning of Earth's space history to the time of *STAR TREK III*. Also included are detailed sections on the changes made since the time of the TV series in the governments of the Klingons, Romulans, Gorn, Orions, and Tholians. Sections on the UFP and Star Fleet Command, complete with photographs and illustrations, give the latest information on uniforms, insignia, equipment, sidearms, and shipboard systems. A starship recognition file gives pictures and data for the *Enterprise*, the *Bird Of Prey* and the other starships. The personnel file gives the updated statistics on your favorite characters from the movies.

> In addition to all this, a complete adventure — *Lost And Presumed Dead* — is included so you can use all the new information.

ISBN 0-931787-24-6 FASA700